

# **Capture Simulation for ILC Electron-Driven Positron Source**

**April 22, 2014**

Y. Seimiya, M. Kuriki, T. Okugi, T. Omori, M. Satoh, J.  
Urakawa, and S. Kashiwagi

# Chart of Positron Source for ILC

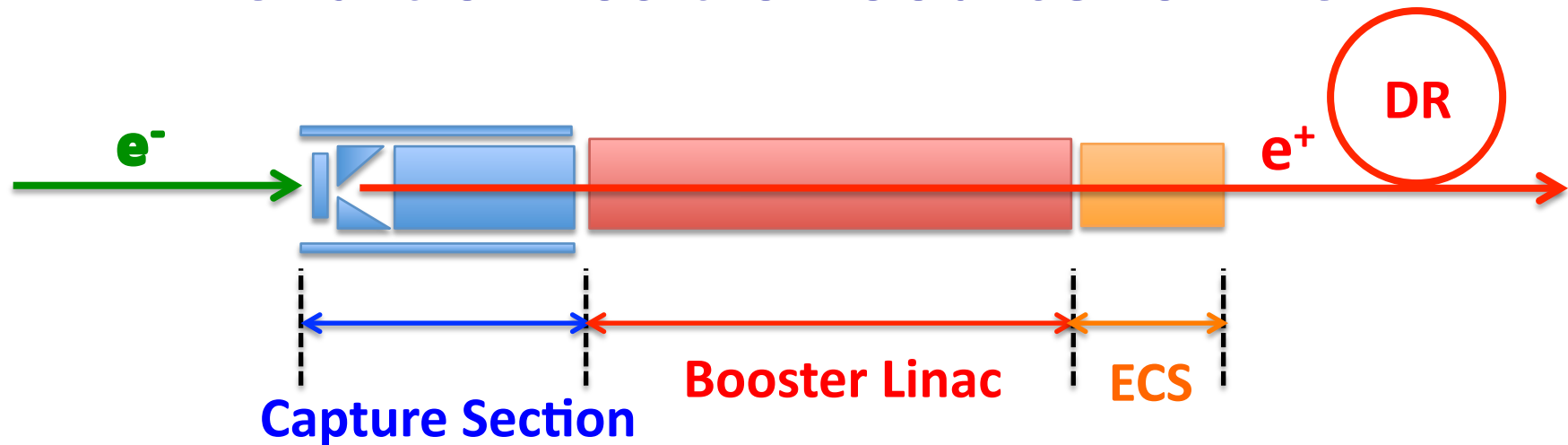

- **Capture Section:**

Transverse momentum is compensated by AMD and solenoid up to several hundreds MeV.

- **Booster Linac:**

Acceleration up to 5GeV.

- **ECS (Energy Compression System):** matching in longitudinal phase space.

- **Yield( $e^+/e^-$ ):**

**The number of  $e^+$  / The number of  $e^-$  at the target**

# Chart of Positron Source for ILC

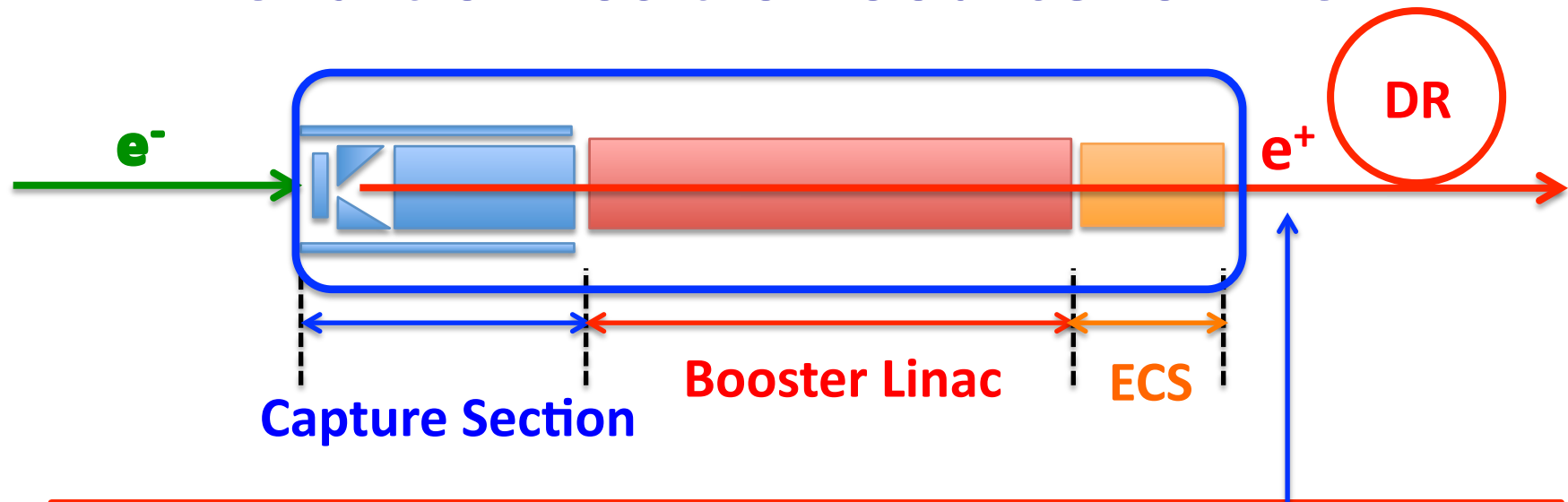

Design guideline is Yield 1.5 at the end of ECS.  
(50% margin to guarantee an enough amount  
of  $e^+$  at IP.)

- Yield( $e^+/e^-$ ):  
The number of  $e^+$  / The number of  $e^-$  at the target

# Typical parameters of Capture Section

## Solenoid

Beam parameters & Target	
Drive beam energy	6 GeV
Beam size	4.0 mm (RMS)
Target thickness	14 mm
AMD parameters	
Max AMD field	7 T
Taper parameter	60.1 /mm
AMD length	214 mm
Solenoid	
Solenoid Field	0.5 T
Accelerating Structure	
RF Gradient	25 MV/m
RF frequency	1.3 GHz (L-band)
Length	10m
Aperture (radius)	20mm

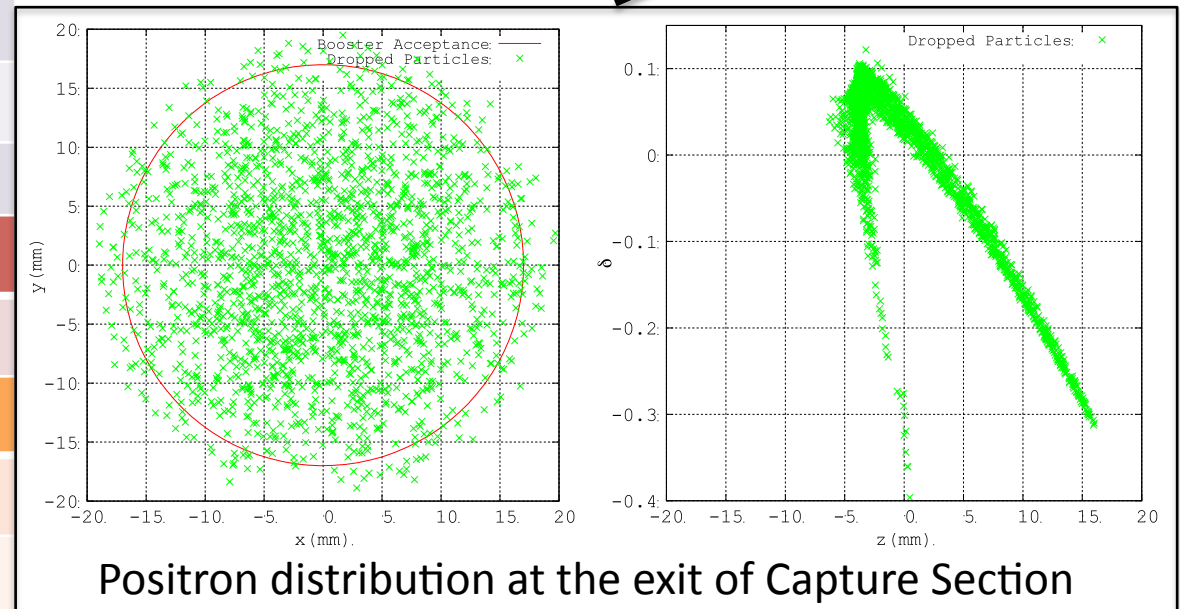
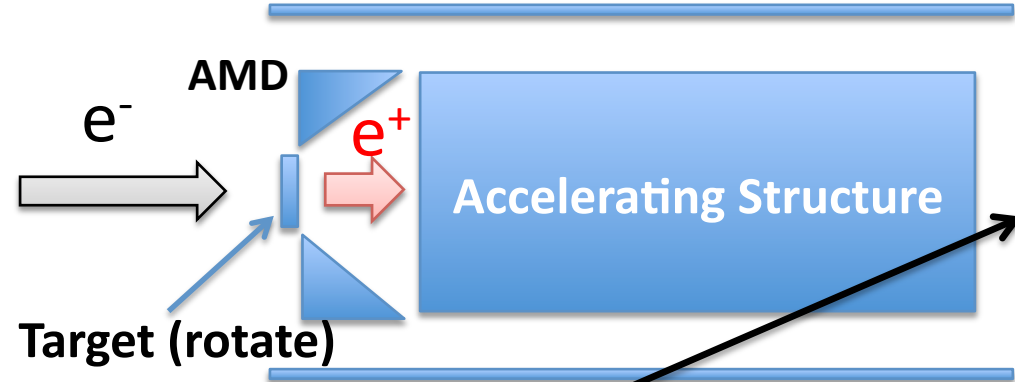

Positron distribution at the exit of Capture Section

- Positron distribution simulated by GEANT4 just after the Target. (T. Takahashi)
- The number of e-: 1000, The number of e+: 12696

# Booster Linac

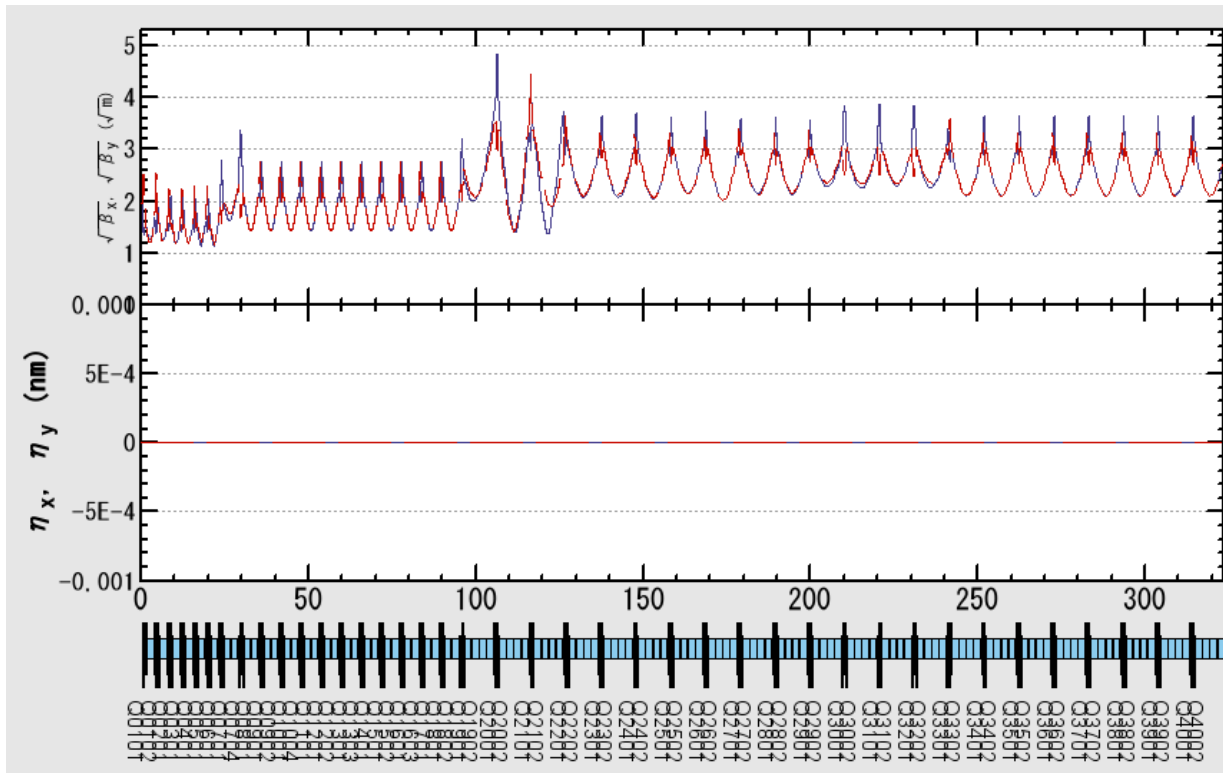

Basic structures are FODO cells consisted of 4 QMs and some RF.

Booster Linac	
RF Peak Gradient	40 MV
RF frequency	1.3 GHz (L-band)
Length	323.6 m
Aperture (radius)	17mm

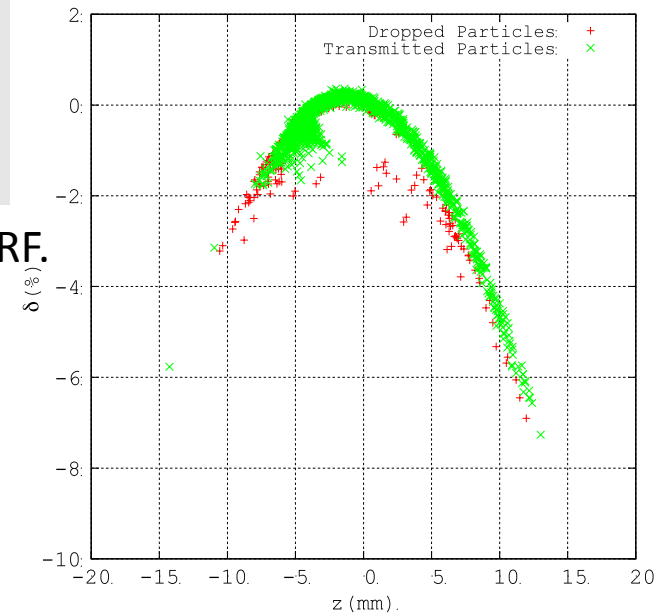
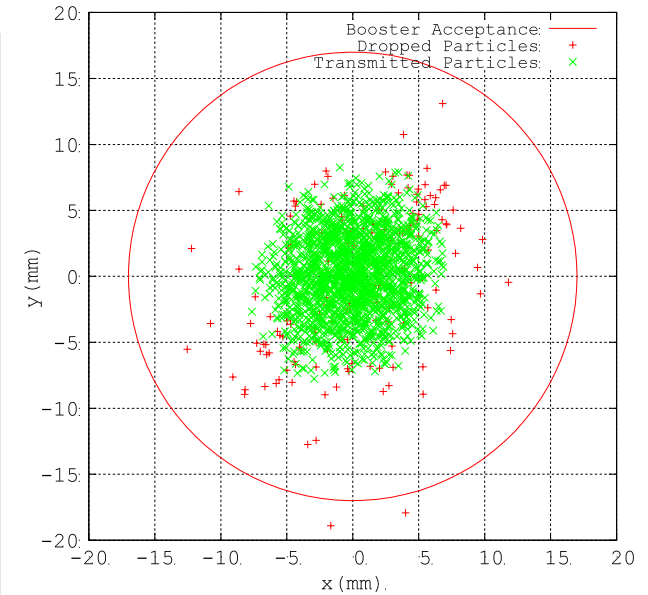

Positron distribution at the exit of Booster Linac

# Energy Compression System (ECS)

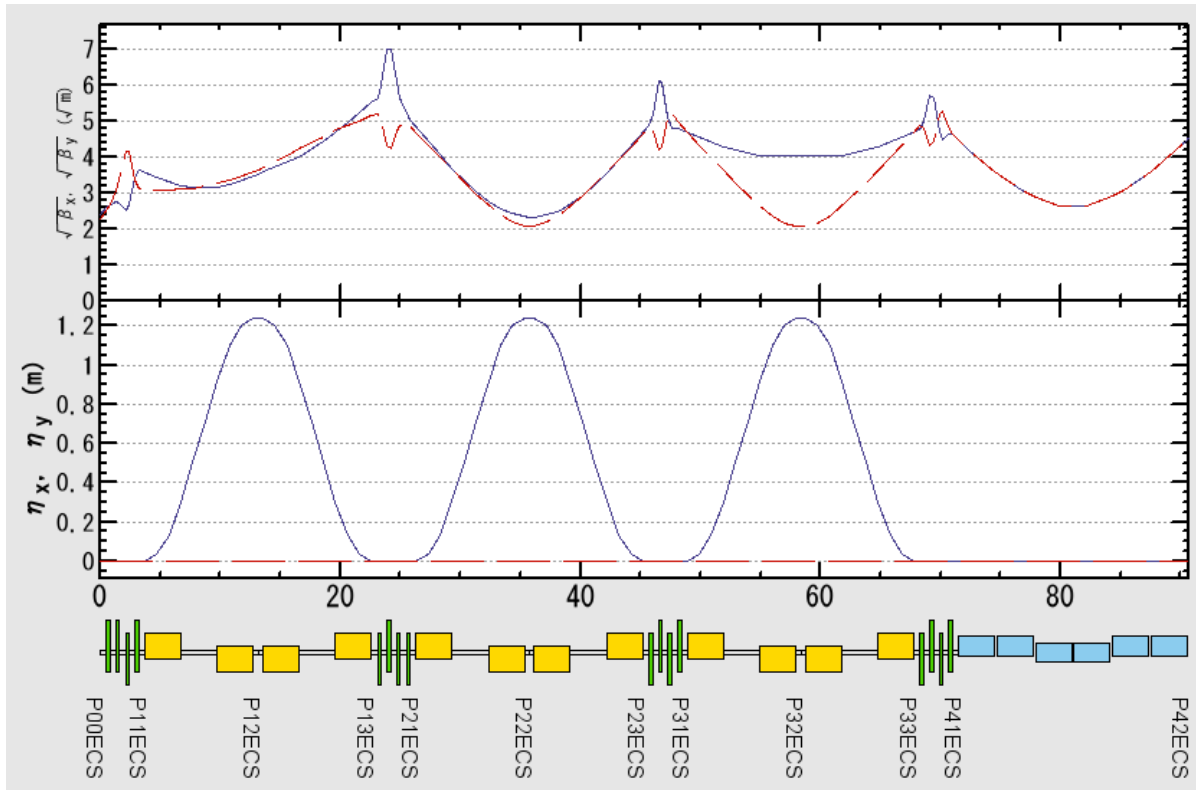

Base structures are 3 chicanes and some RF.

ECS	
RF Peak Gradient	38 MV
RF frequency	1.3 GHz (L-band)
Length	90.5 m
Aperture (radius)	17mm

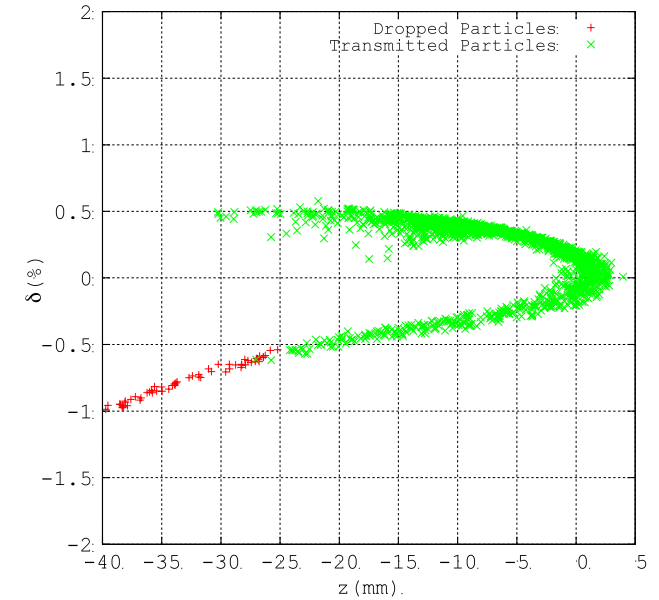
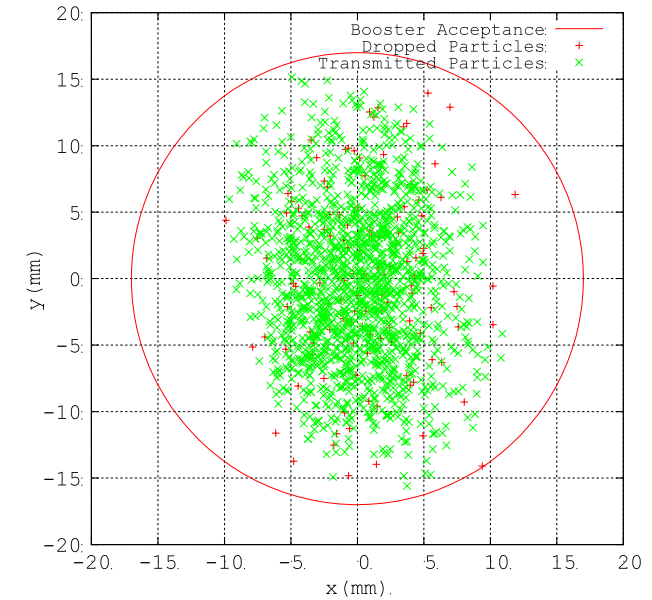

Positron distribution at the exit of ECS

# Impact of some parameters to Yield

1. RF phase at Capture Section
2. RF phase at Booster Linac, ECS
3. Aperture at Capture Section
4. Aperture at Booster Linac, ECS
5. Aperture and magnetic strength at AMD, and distance between AMD and target
6. Drive beam energy, target thickness, and beam size
7. Magnetic strength of Solenoid
8. RF gradient at Capture Section
9. Positron energy at the exit of Capture Section

# Impact of some parameters to Yield

1. RF phase at Capture Section
2. RF phase at Booster Linac, ECS optimized inside program
3. Aperture at Capture Section realistic largest aperture
4. Aperture at Booster Linac, ECS
5. Aperture and magnetic strength at AMD, and distance between AMD and target
6. Drive beam energy, target thickness, and beam size
7. Magnetic strength of Solenoid small impact with large aperture (~20mm)
8. RF gradient at Capture Section small impact
9. Positron energy at the exit of Capture Section

# Impact of some parameters to Yield

1. RF phase at Capture Section
  2. RF phase at Booster Linac, ECS optimized inside program
  3. Aperture at Capture Section realistic largest aperture
  4. Aperture at Booster Linac, ECS
  5. Aperture and magnetic strength at AMD, and distance between AMD and target
  6. Drive beam energy, target thickness, and beam size
  7. Magnetic strength of Solenoid small impact with large aperture (~20mm)
  8. RF gradient at Capture Section small impact
  9. Positron energy at the exit of Capture Section small impact
- **4, 5, and 6 are checked with same phase since they hardly depend on RF phase.**

# RF phase in Capture Section

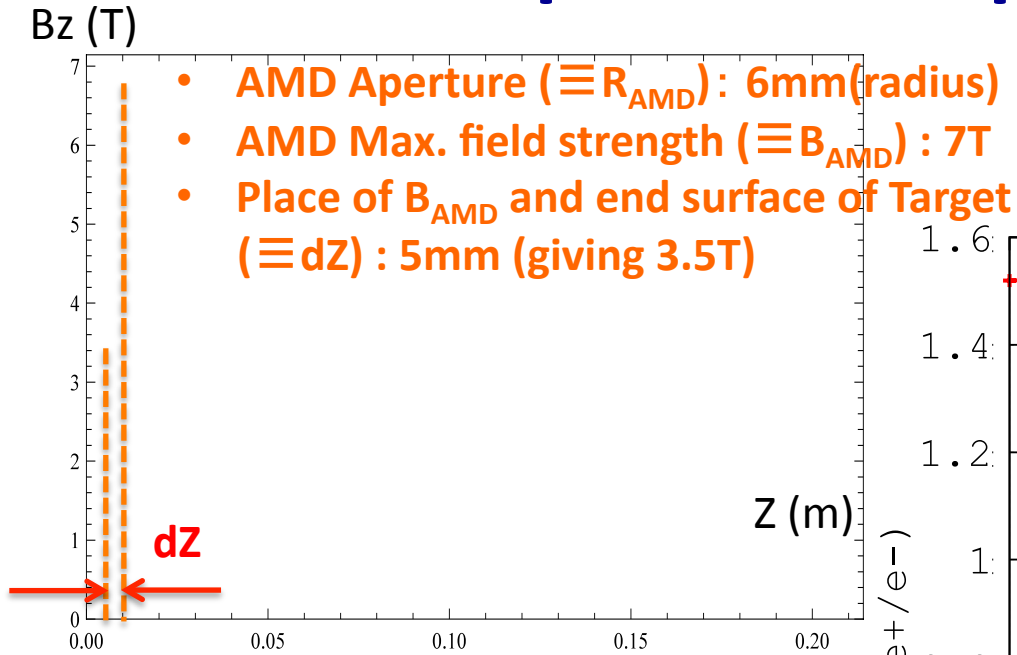

- Aperture at Capture Section  
 $(X^2+Y^2)^{1/2} < 20$  mm
- Aperture at Booster Linac  
 $(X^2+Y^2)^{1/2} < 17$  mm
- Acceptance at DR
  - Longitudinal Acceptance:  
 $(E-E_0)/E_0 < 0.75$  %,  $(z-z_0) < 37.5$  mm
  - Transverse Acceptance:  
 $(W_x+W_y)*\gamma < 70$  mm

6GeV-Sigma4mm-Target14mm-AMDAp6mm-DZ5mm ECS

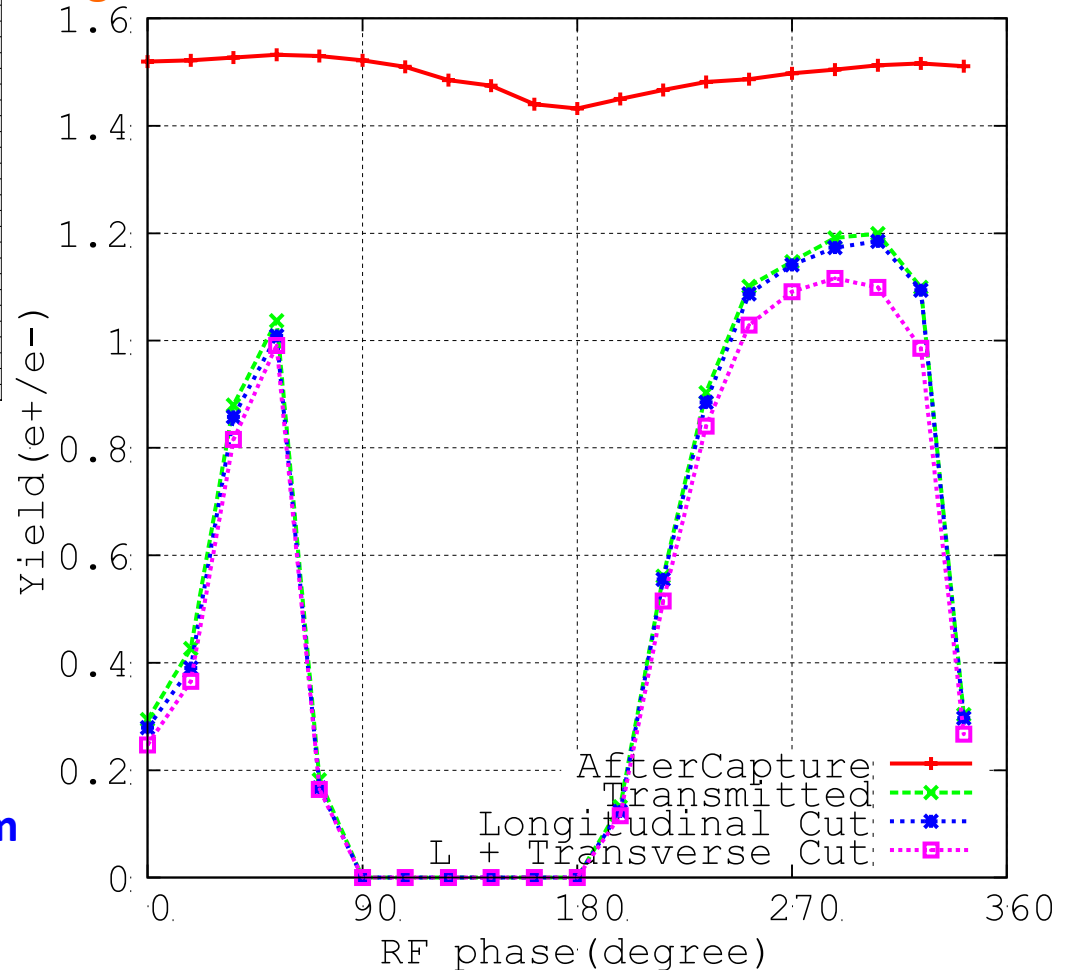

# RF phase in Capture Section

Yield is Max. at 270° ~ 310°

- Aperture at Capture Section  
 $(X^2+Y^2)^{1/2} < 20$  mm
- Aperture at Booster Linac  
 $(X^2+Y^2)^{1/2} < 17$  mm
- Acceptance at DR
  - Longitudinal Acceptance:  
 $(E-E_0)/E_0 < 0.75$  %,  $(z-z_0) < 37.5$  mm
  - Transverse Acceptance:  
 $(W_x+W_y)*\gamma < 70$  mm

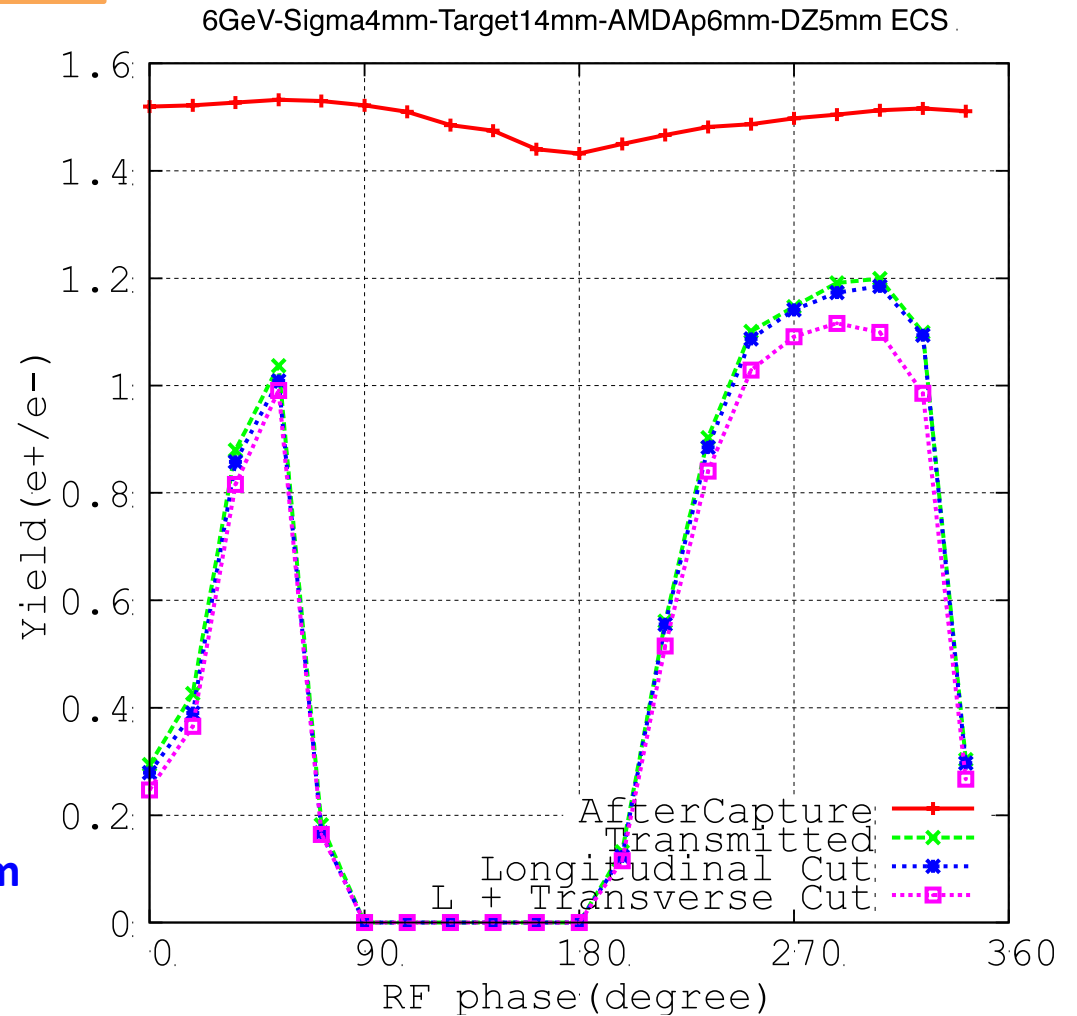

# Aperture in Booster Linac

**17mm is enough for aperture in Booster Linac**

- Aperture at Capture Section  
 $(X^2+Y^2)^{1/2} < 20$  mm
- Aperture at Booster Linac  
 $(X^2+Y^2)^{1/2} < \text{Horizontal Axis}$
- Acceptance at DR
  - Longitudinal Acceptance:  
 $(E-E_0)/E_0 < 0.75\%$ ,  $(z-z_0) < 37.5$  mm
  - Transverse Acceptance:  
 $(W_x+W_y)*\gamma < 70$  mm

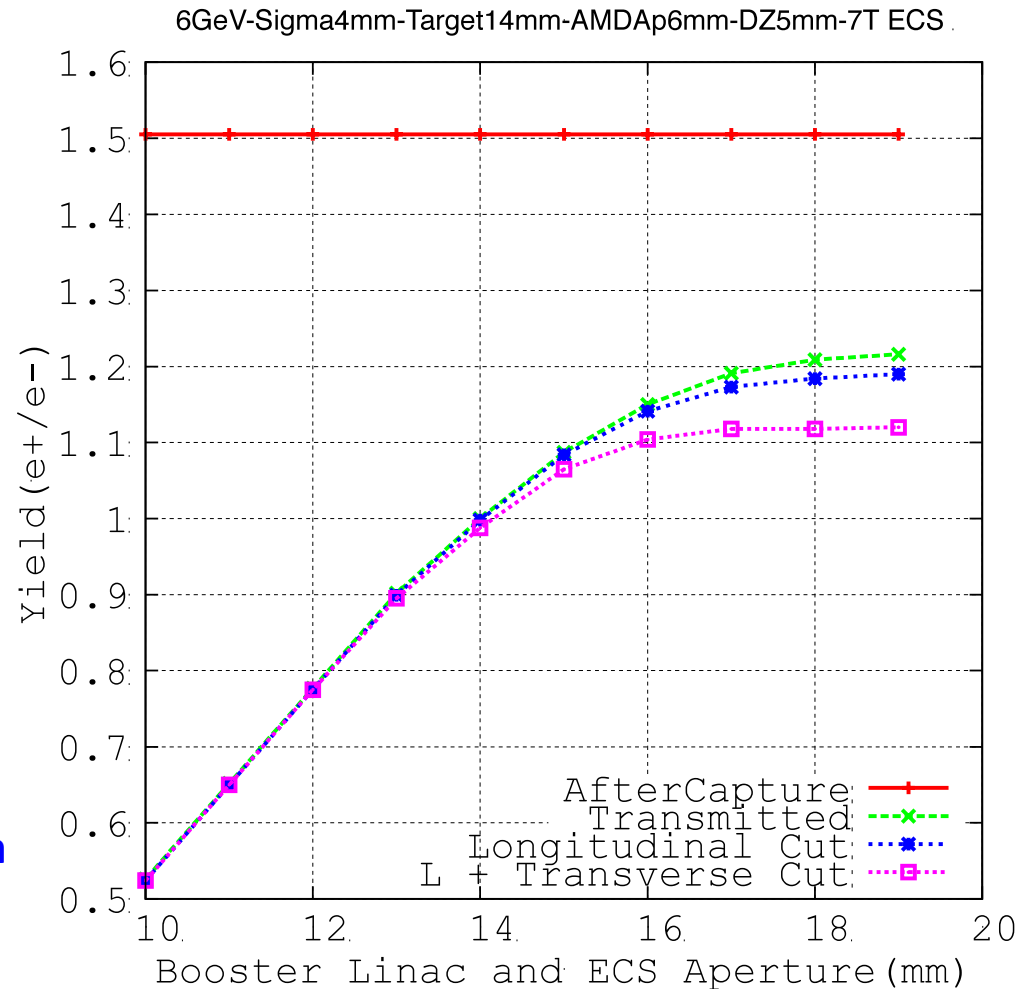

# AMD and Target configurations

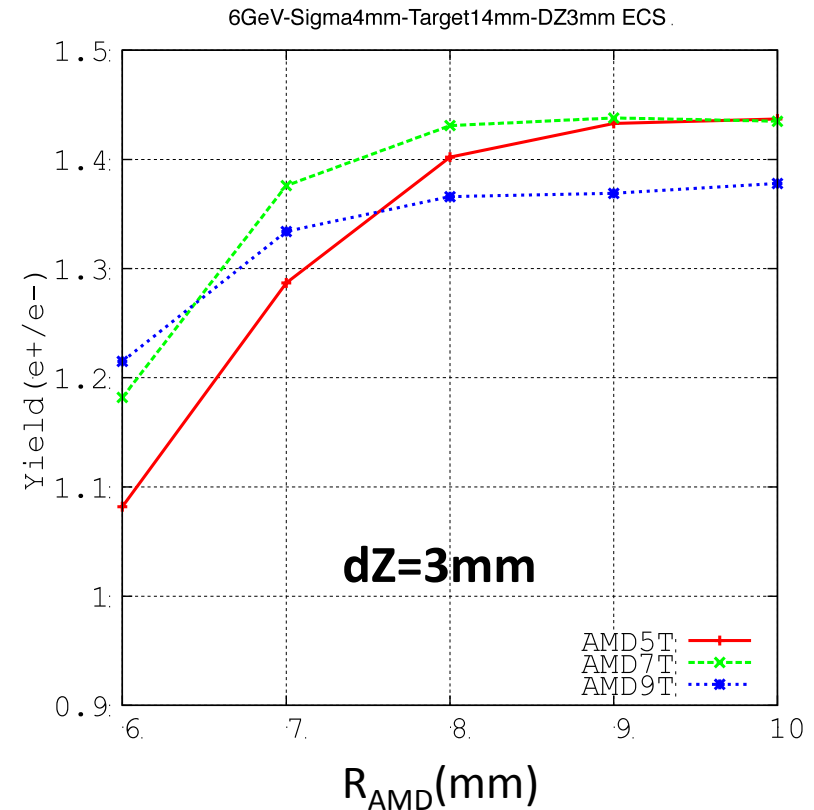
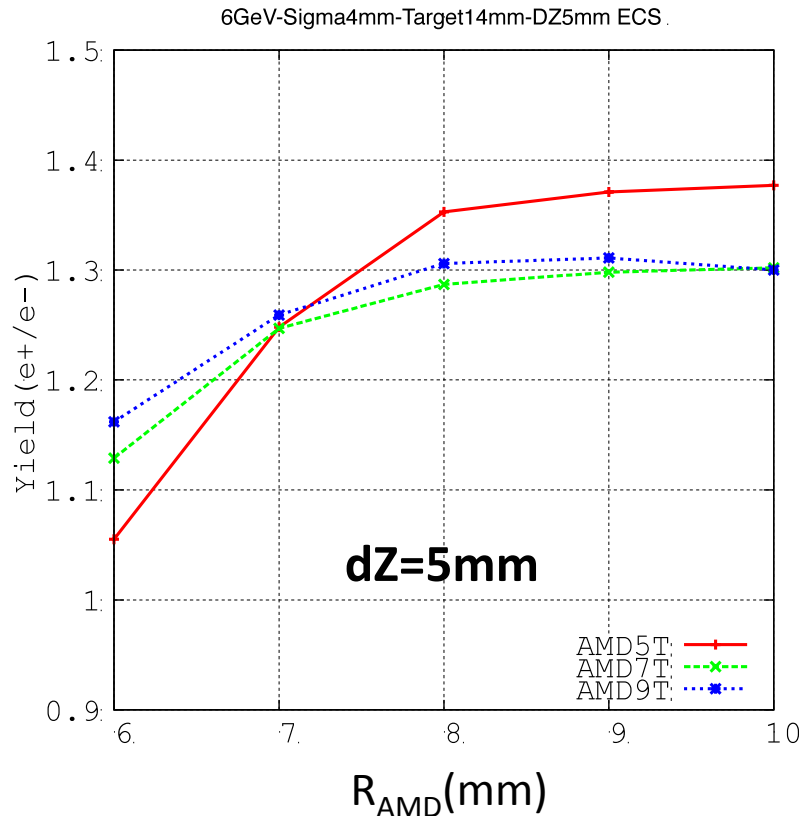

- Yield is greatly depended on  $R_{AMD}$  and dZ.
- But not so much on peak  $B_{AMD}$ .
- Yield is saturated at  $dZ < 3\text{mm}$  and  $R_{AMD} > 8\text{mm}$ .
- $B_{AMD} = 7\text{T}$ ,  $dZ = 3\text{mm}$ , and  $R_{AMD} = 8\text{mm}$  are a feasible parameter set.

# Drive beam and Target configuration (1)

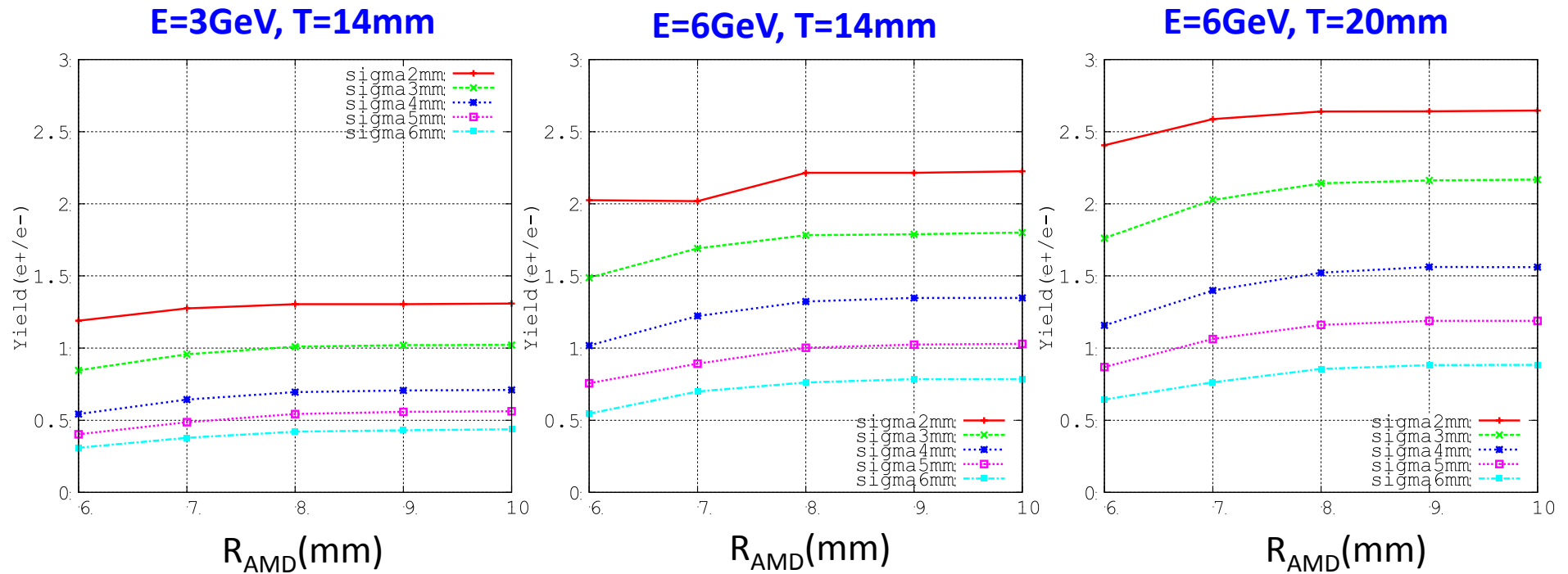

Energy	Thickness	PEDD at $2e^{10}$
3 GeV	14 mm	17 J/g
6GeV	14 mm	26 J/g
	20 mm	26 J/g

# Drive beam and Target configuration (2)

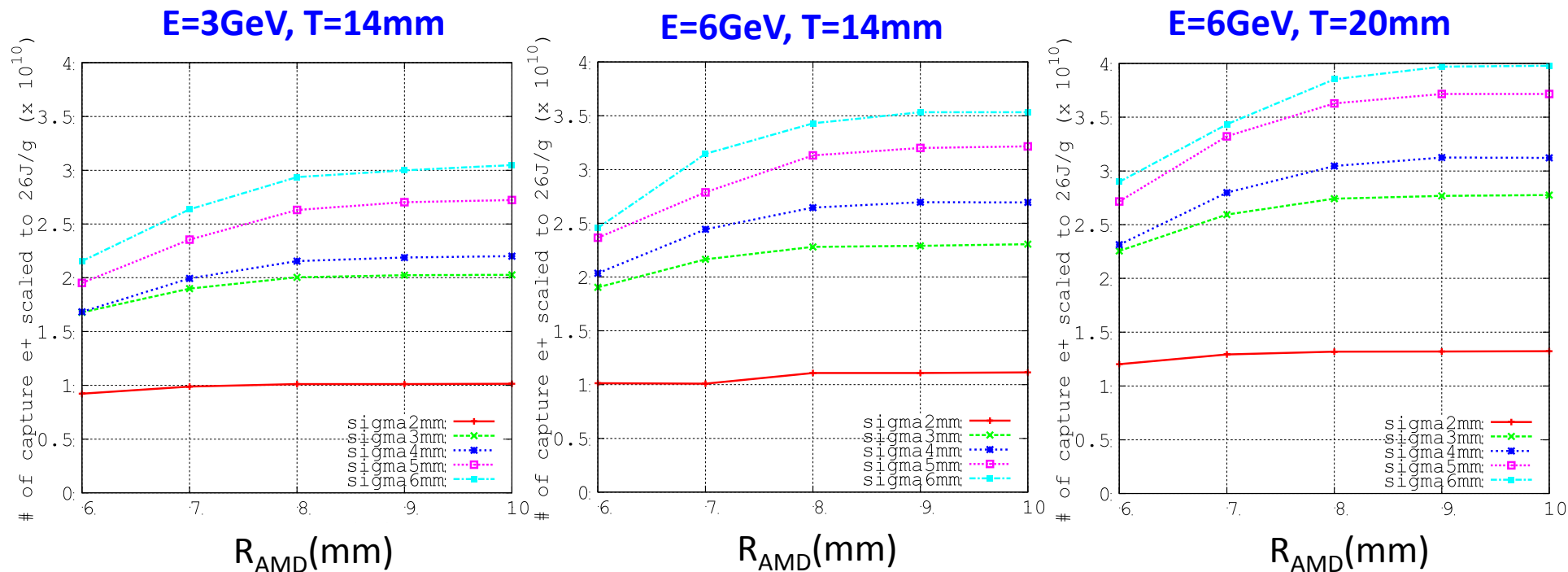

Energy	Thickn ess	PEDD at 2e10 e	# of e- giving 26J/g
3 GeV	14 mm	17 J/g	3.1e10
6GeV	14 mm	26 J/g	2.0e10
	20 mm	26 J/g	2.0e10

- **Scaling # of electron giving PEDD 26 J/g.**
- **Larger spot size gives larger # of e+.**
- **Yield is better for smaller spot size.**
- **6GeV, T=20mm might be optimum.**

# Replacing L-> S-band(1)

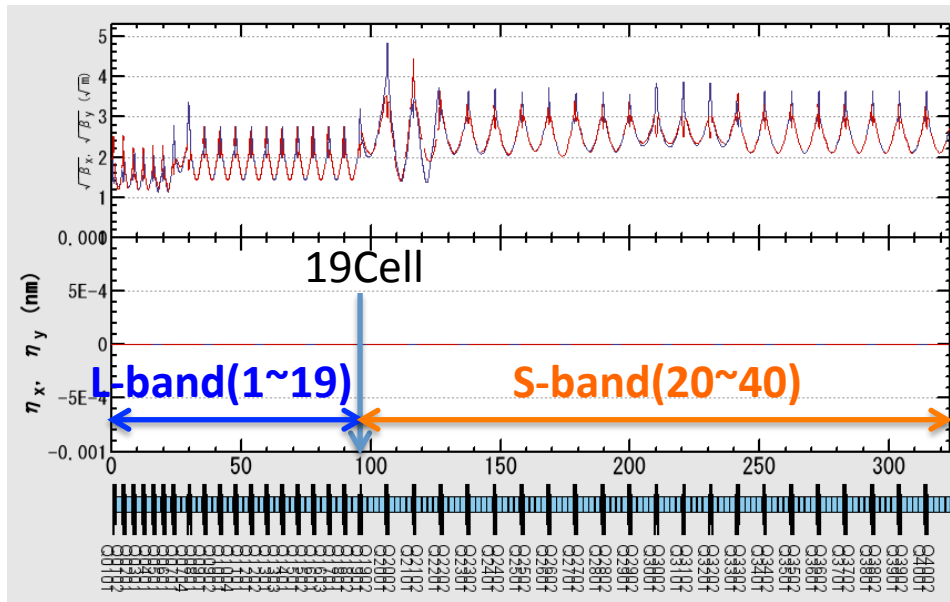

- 1-6 Cell = (2FODO +RF)**
- 7~18Cell = (2FODO+2RF)**
- 19~40Cell = (2FODO+ 4RF)**

- **Capture Section**
  - **L-band RF Aperture: 20 mm**
- **Booster Linac**
  - **L-band RF Aperture: 17 mm**
  - **S-band RF Aperture: 10 mm**
- **ECS Aperture: 17mm**

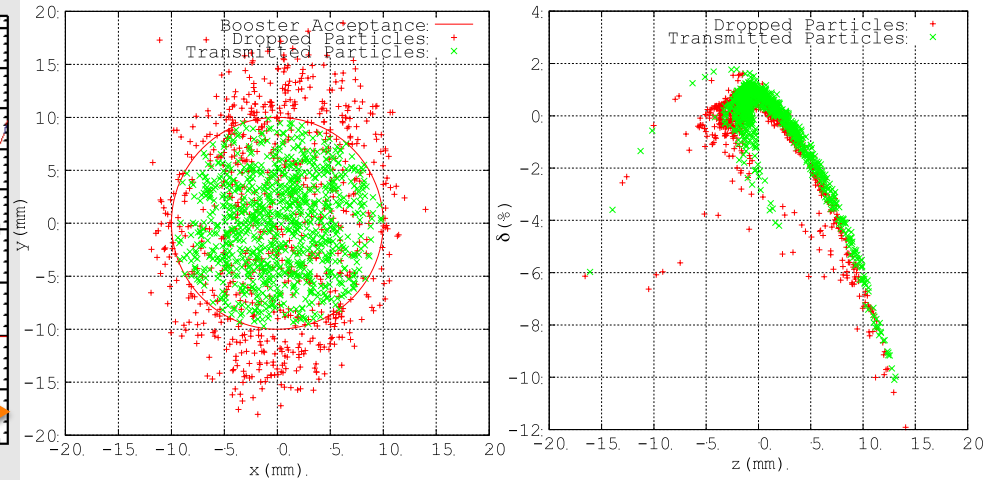

20Cell (starting point of S-band)

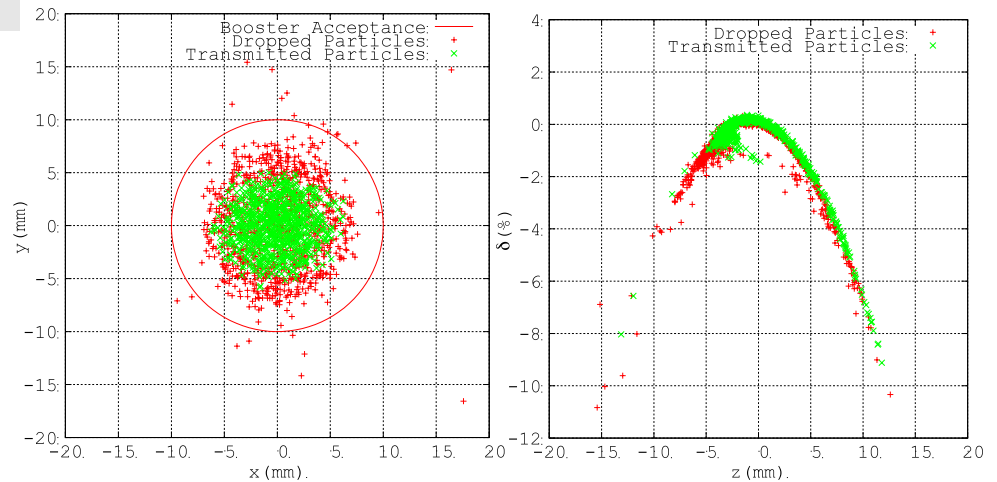

Exit of Booster Linac

# Replacing L->S-band (2)

6GeV-Sigma4mm-Target14mm-AMDAp8mm-DZ3mm-5T ECS.

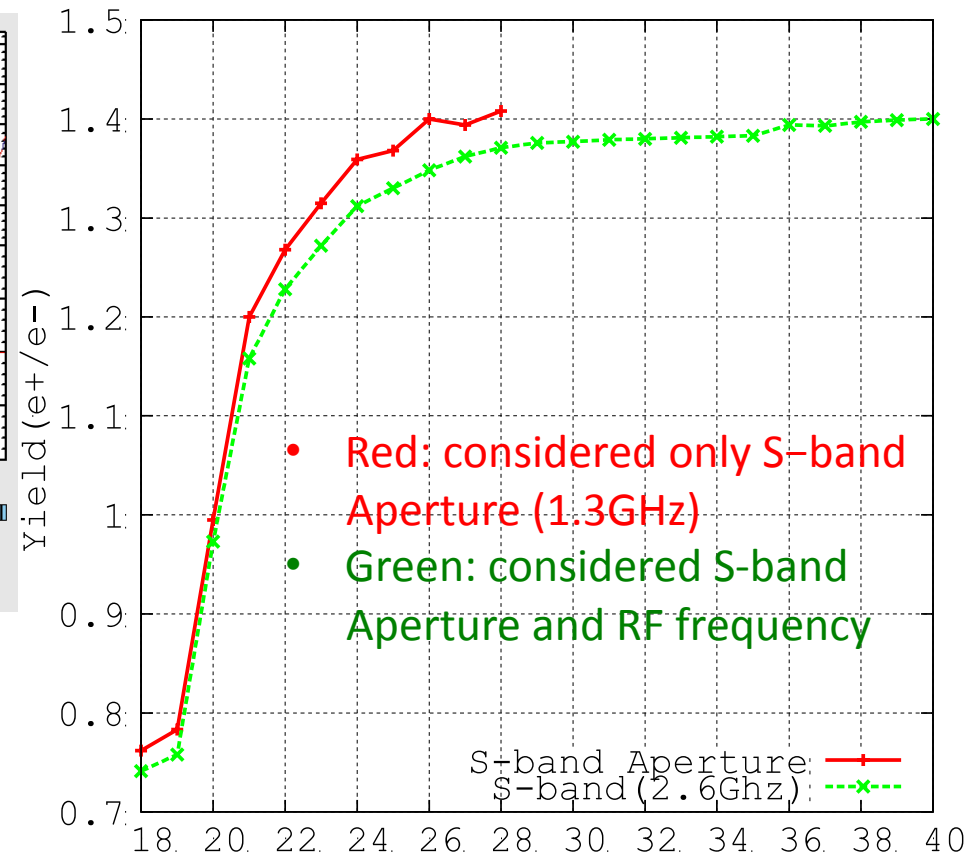
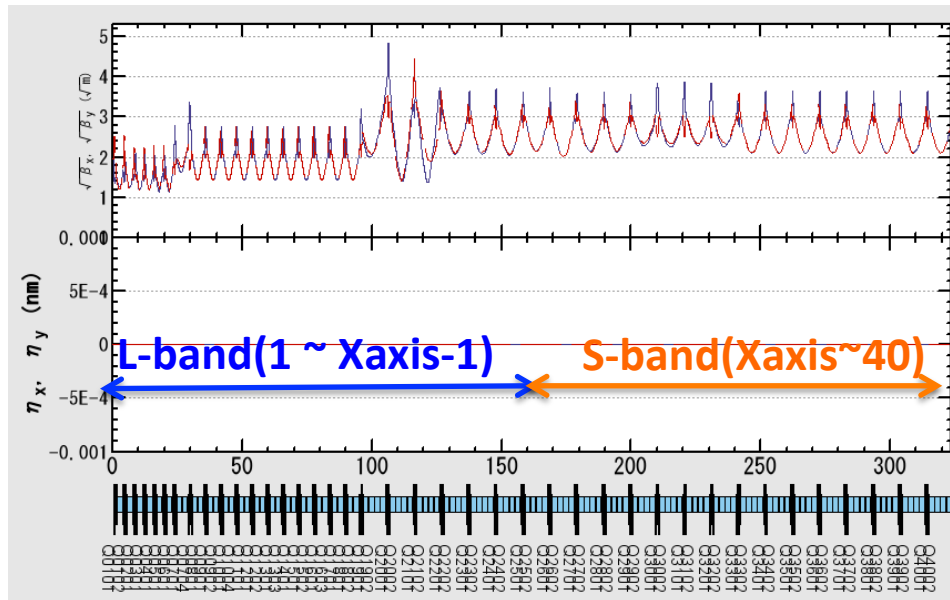

**Nc : Cell number where S-band starts**

- 1-6 Cell = (2FODO + RF)**
- 7~18Cell = (2FODO+2RF)**
- 19~40Cell = (2FODO+ 4RF)**

- **Capture Section**
  - **L-band RF Aperture: 20 mm**
- **Booster Linac**
  - **L-band RF Aperture: 17 mm**
  - **S-band RF Aperture: 10 mm**
- **ECS Aperture: 17mm**

$$\text{L-band RF} = 6 + 12 \cdot 2 + (\text{Nc} - 18) \cdot 4$$

$$\text{S-band RF} = (40 - \text{Nc}) \cdot 4$$

$$\text{Nc} = 26 \text{ giving L-band: } 62 \text{ and S-band: } 56$$

# FC and Solenoid of SuperKEKB

Applied only  
SuperKEKB FC

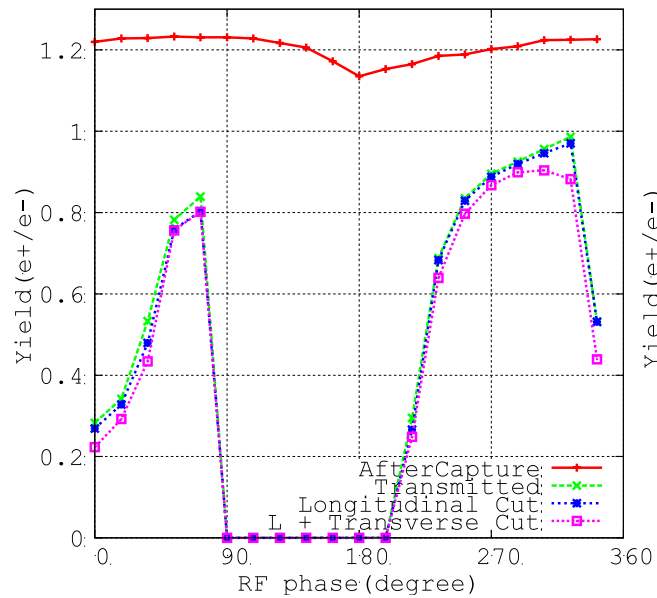

Applied only  
SuperKEKB solenoid

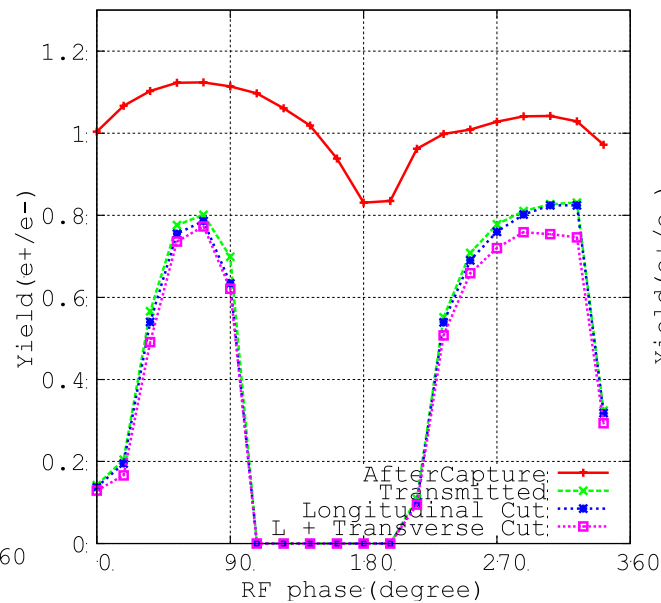

Applied FC and solenoid  
of SuperKEKB

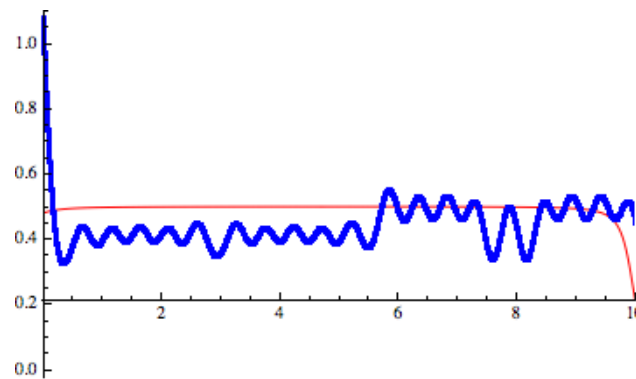
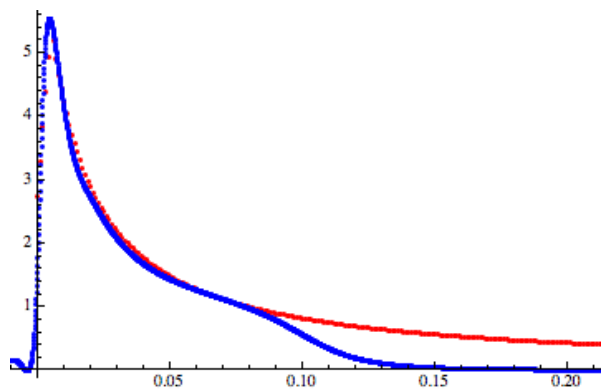
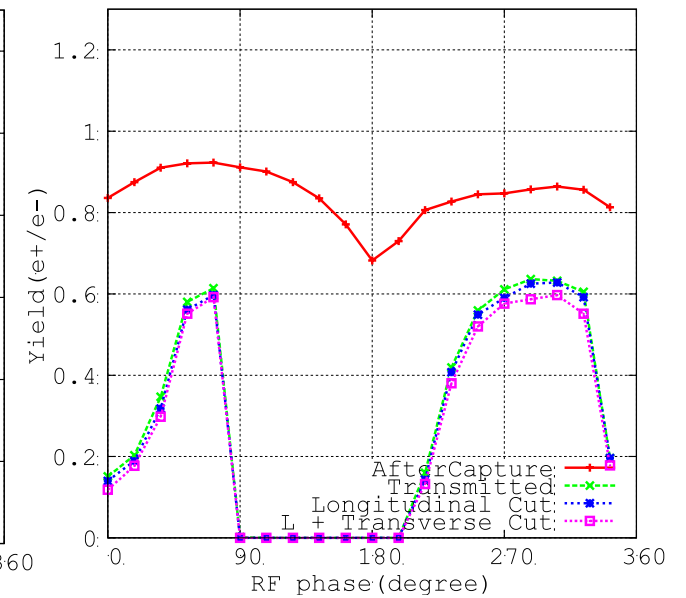

# Beam loading by electron

- Many electrons are also generated by the target.
- These electron are captured in RF phase opposite to that for positron .
- Total beam loading becomes roughly twice of that by positrons.
- The electrons can be eliminated by a chicane.
- However, the chicane at low energy causes a significant loss on the capture efficiency.
- The position of the chicane is compromised between the beam loading and the capture efficiency.

# SUMMARY

- Positron Capture for ILC Electron-Driven Positron Source is simulated.
- Yield( $e^+/e^-$ ) is greatly depended on AMD aperture, target position, and beam size. When  $E=6\text{GeV}$ ,  $T=20\text{mm}$ ,  $\sigma>5\text{mm}$ ,  $dZ=5\text{mm}$ ,  $R_{\text{AMD}}>7\text{mm}$ , and  $B_{\text{AMD}}=5\text{T}$ , enough  $e^+$  is obtained.
- Yield reduce greatly when FC and solenoid of SuperKEKB. Investigation of the reason is necessary.
- Need an optimization of the chicane position.