

Four-mirror Fabry-Perot cavity R&D at ATF

1. Our setup/goal
2. Why 4 mirrors ?
3. The ATF 4-mirror cavity
4. The optical scheme
5. The laser/cavity feedback

F. Zomer
2-Sep-2010
ILC-CLIC e+ studies

French Japanese Collaboration

F. Labaye, E. Cormier, CELIA CNRS Université Bordeaux 1, Bordeaux, France
T. Akagai, S. Miyosohi, S. Nagata, T. Takahashi, Hishoshima University Hiroshima, Japan
S. Araki, S. Funahashi, Y. Honda, T. Omori, H. Shimizu, T. Terunuma, J. Urakawa, KEK, Tsukuba, Japan
J. Bonis, R. Chiche, R. Cizeron, M. Cohen, J. Colin, E. Cormier, P. Cornebise, D. Jehanno, F. Labaye, M. Lacroix,
Y. Peinaud, V. Soskov, A. Variola, F. Zomer, LAL CNRS/IN2P3 Université Paris-Sud 11, Orsay, France
N. Delerue] R. Flaminio, L. Pinard, LMA CNRS/IN2P3, Lyon, France

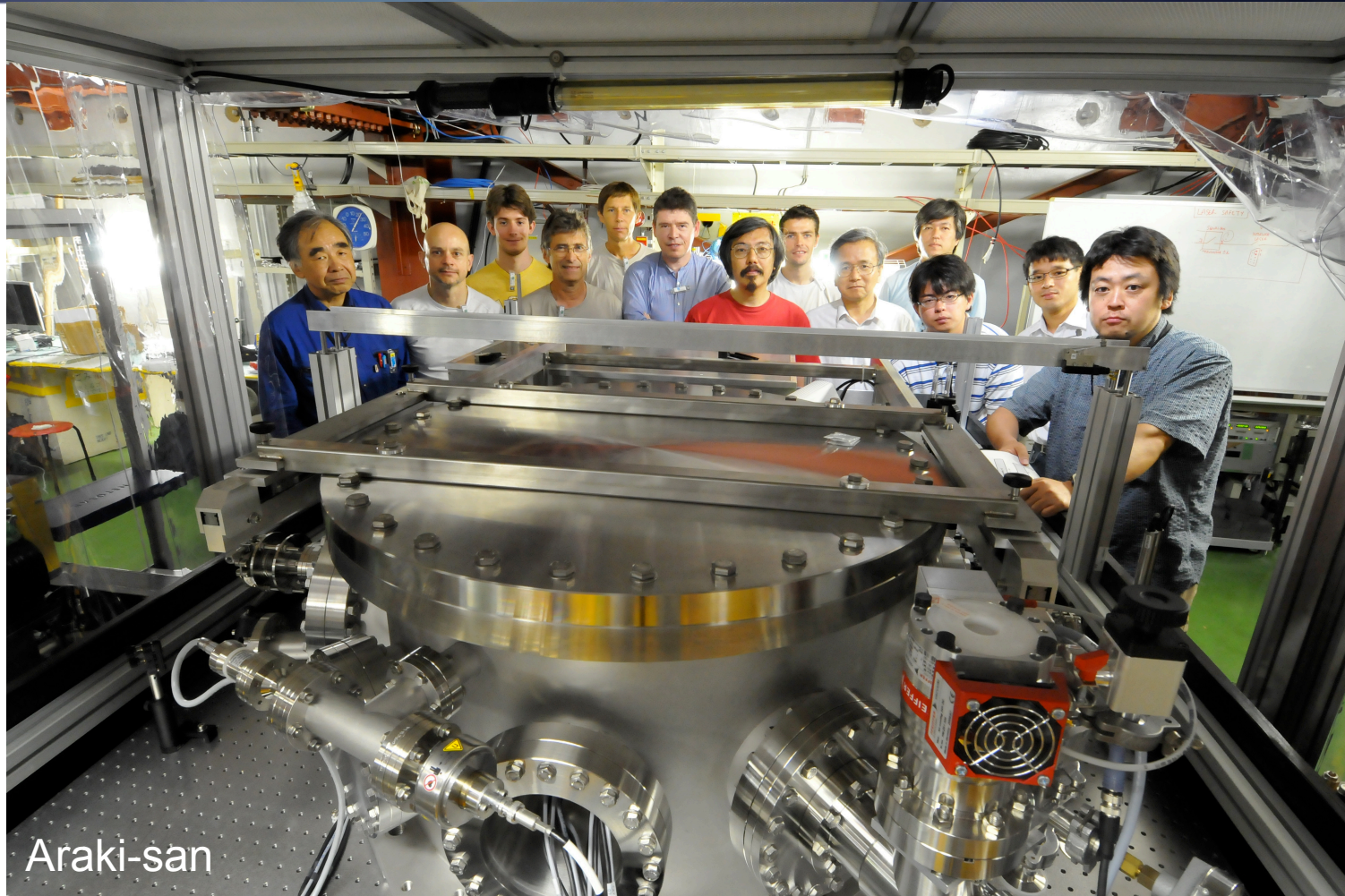

Araki-san

2 steps R&D

Started end 2008

STEP ONE: commissioning a 4-mirror cavity at ATF by end 2010

STEP TWO: upgrade mirrors & laser power

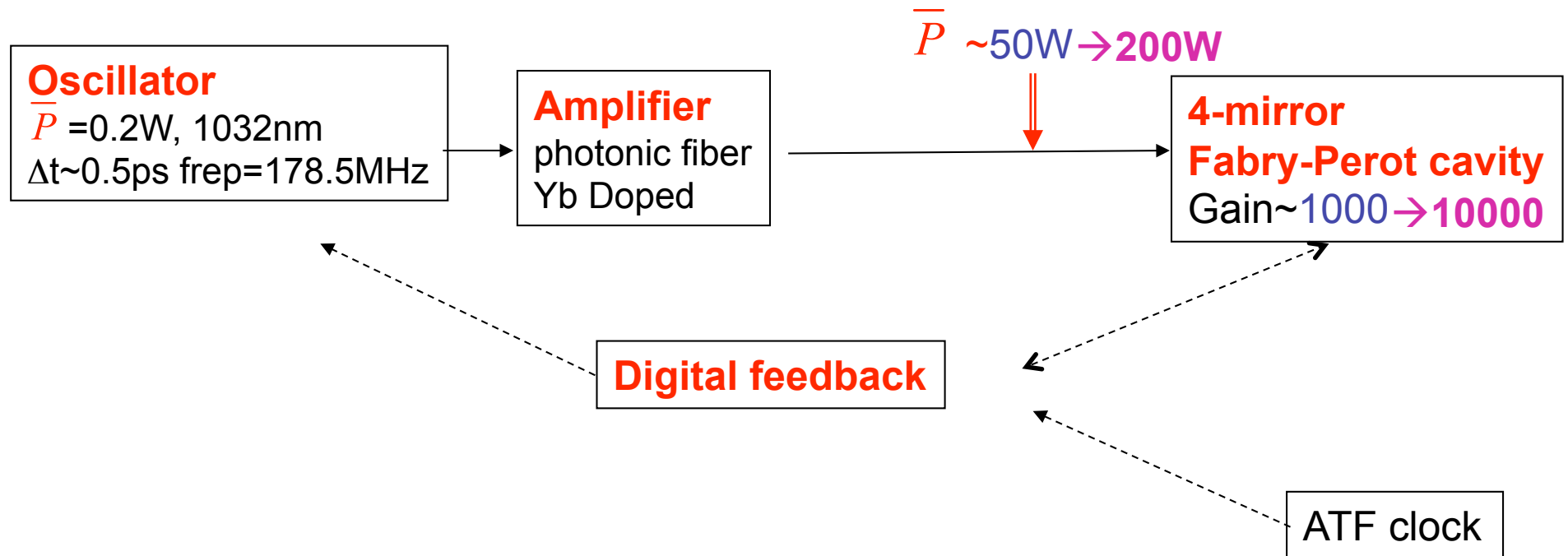

STEP ONE

With cavity laser/coupling $\sim 50\%$ \rightarrow Power_cavity $\sim 25\text{kW}$

$\sim 50 \times 1.5$ vs 2-mirror cavity
 $\rightarrow \sim 5 \text{ E}9 \text{ } \gamma/\text{s}$ ($E_{\text{max}} = 28\text{MeV}$)

STEP TWO

With cavity laser/coupling $\sim 50\%$ \rightarrow Power_cavity $\sim 500\text{kW}$

$\sim 2000 \times 1.5$ vs 2-mirror cavity
 $\rightarrow \sim 2 \text{ E}11 \gamma/\text{s}$

Goal: to reach the MW average power

Why a four-mirror cavity ?

Optical axis in 2-mirror cavity:
Line joining the 2 center of curvature

Ex.: 2 misaligned mirrors

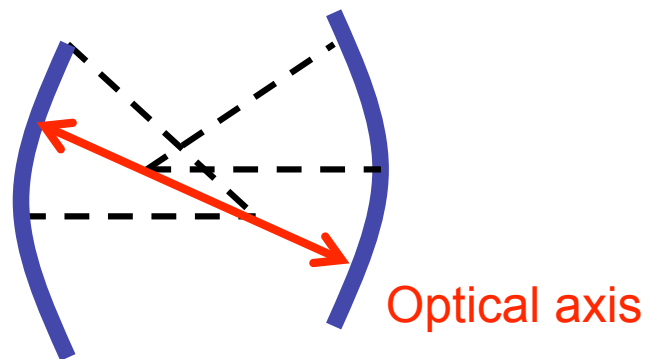

Laser beam spot size decreases
as the cavity becomes concentric
BUT

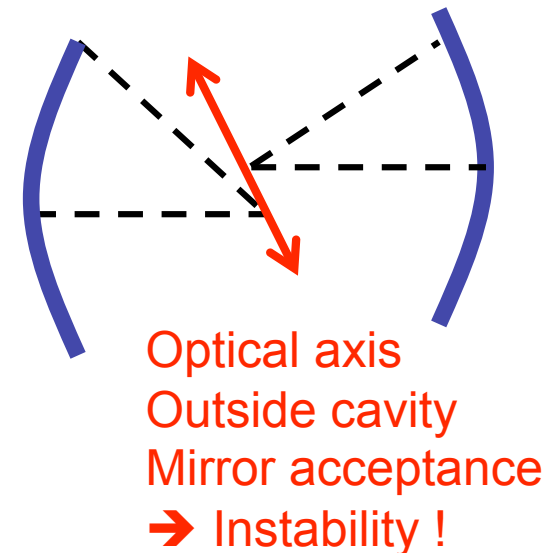

Solution : use a four-mirror cavity which avoids this instability

Why a non planar four-mirror cavity ?

Stable solution: four-mirror cavity
as in Femto laser technology

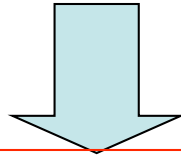

BUT
→ astigmatic & linearly
polarised eigen-modes
which are instable because of vibrations
at very high finesse (AO48(2009)6651)

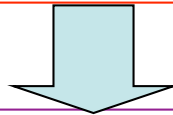

Non-planar 4-mirror cavity
→ **Stable & circularly polarised
eigenmodes (AO48(2009)6651)**
• **New feedback techniques with this geometry**
(Honda, OC282(2009)3108)

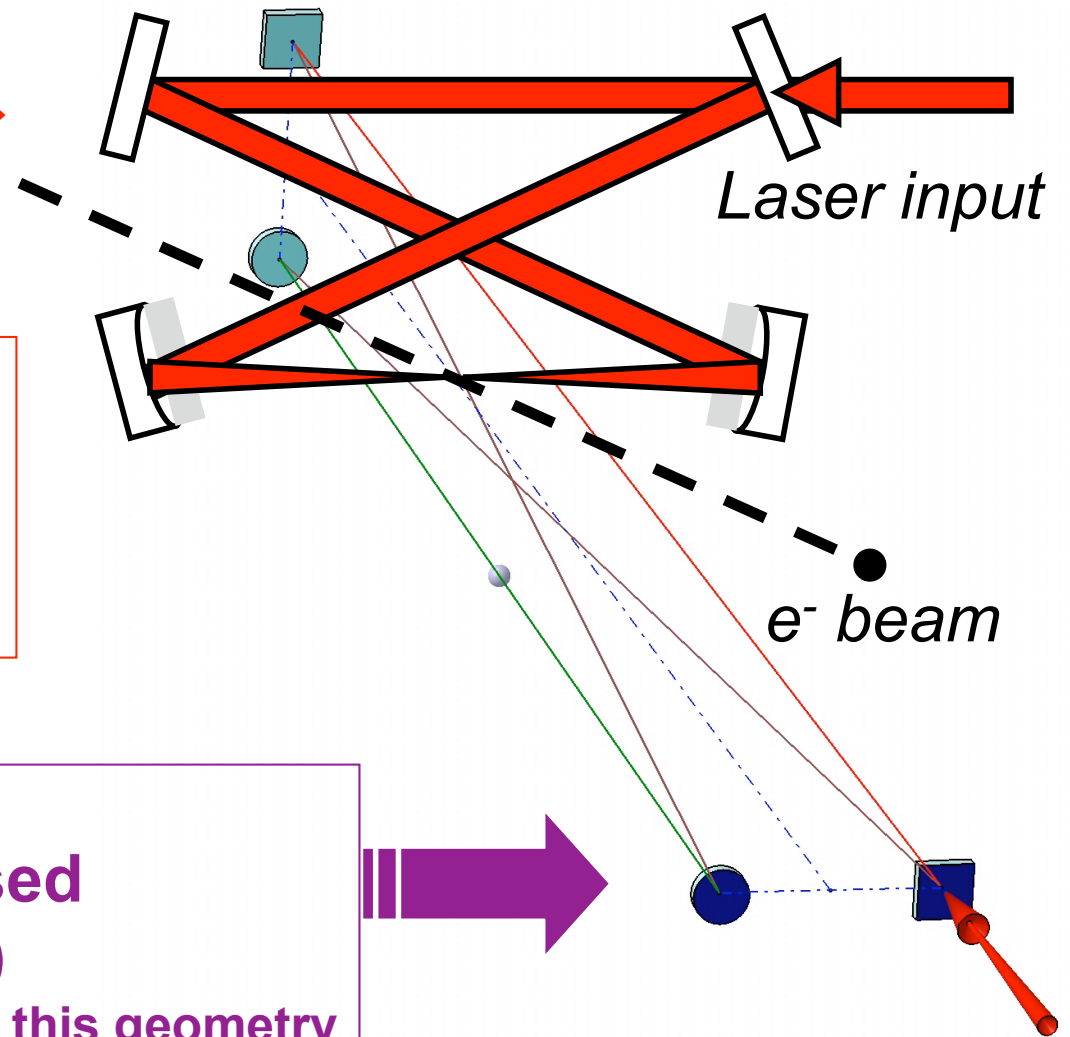

Prototype of nonplanar 4-mirror resonator (low finesse)

- Check the general astigmatism mode shape/propagation (*Arnaud, Bell Syst. Tech. (1970)2311*)
- ok

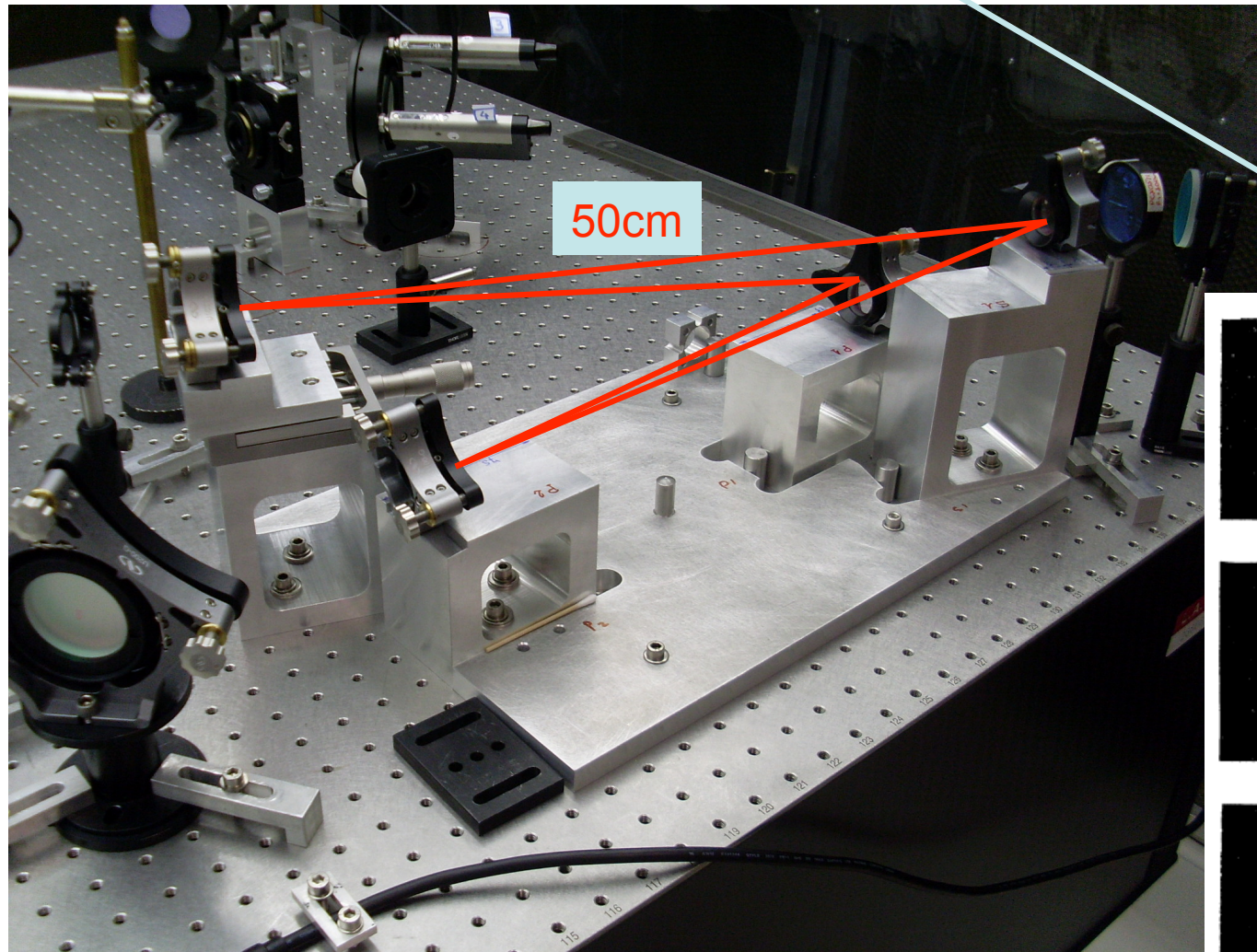

Ellipse intensity profile 'turning'

Kogelnik, Apl. Opt. 8(1969)1687



Z = 10 cm



Z = 20 cm



Z = 30 cm



Z = 40 cm



Z = 50 cm



Z = 60 cm

Non planar 4-mirror cavity design/construction for ATF

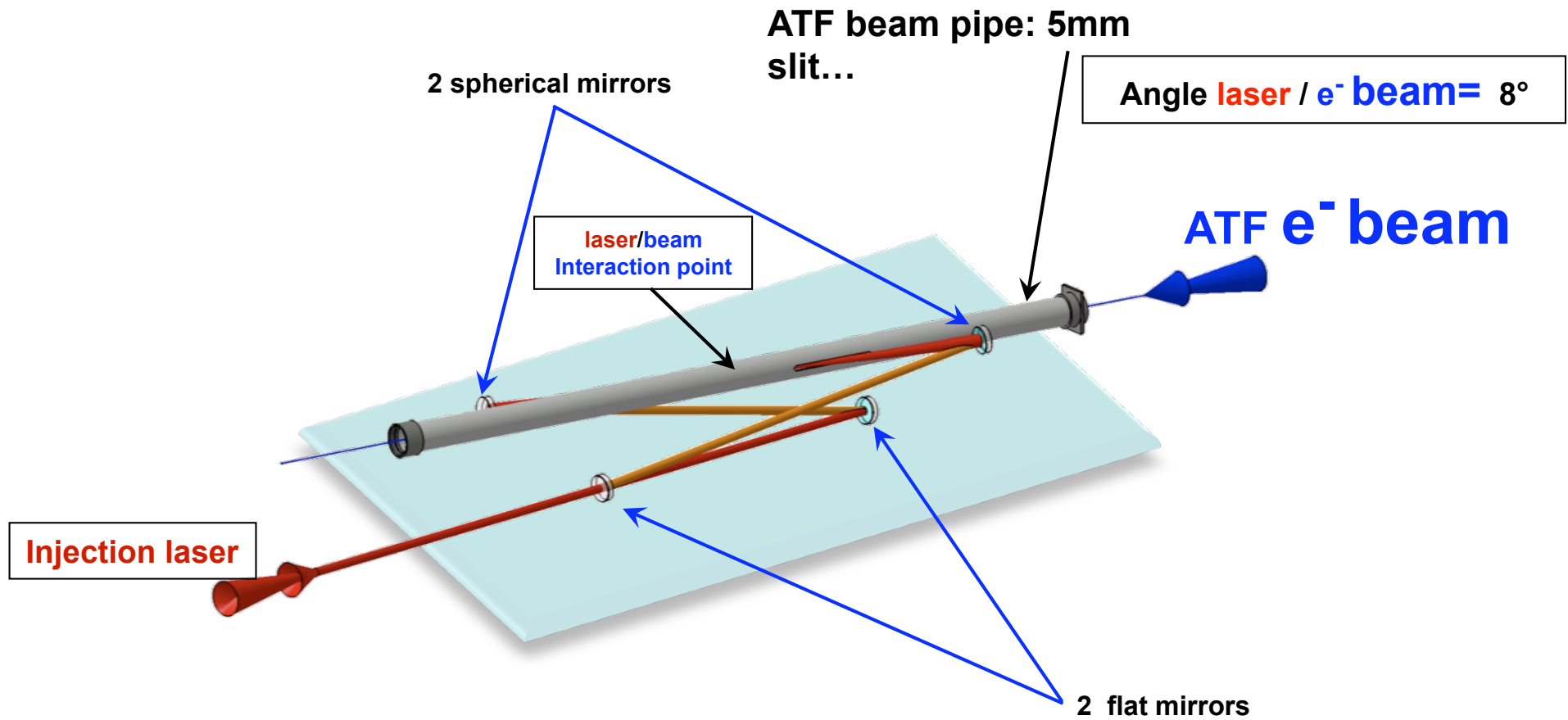

Mirror positioning system

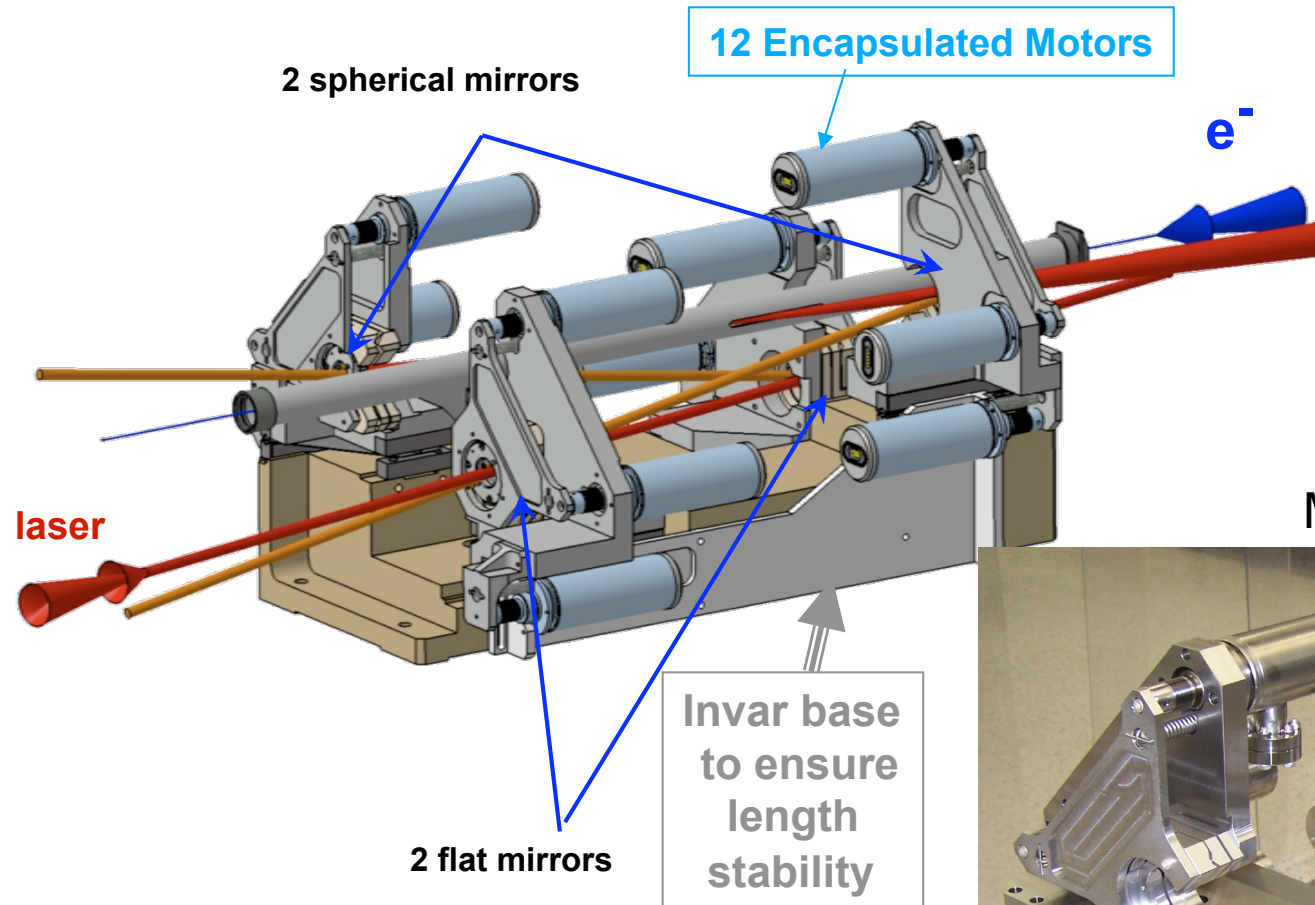

Mounting in class 10 room

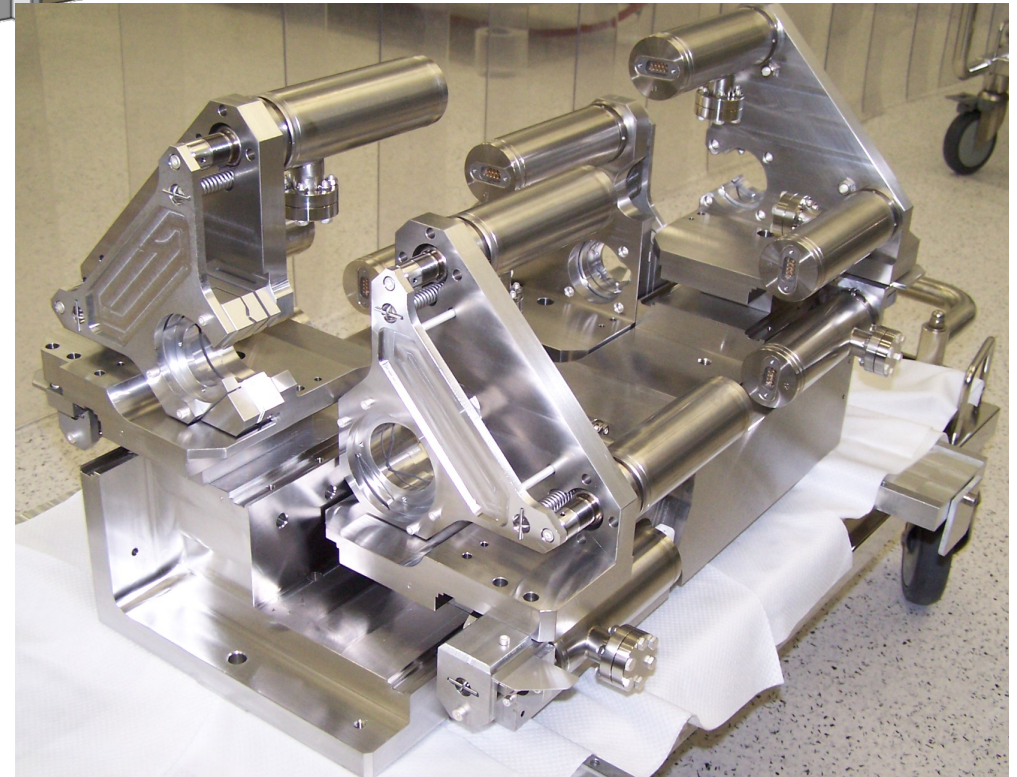

OVERALL DESIGN PRINCIPLE

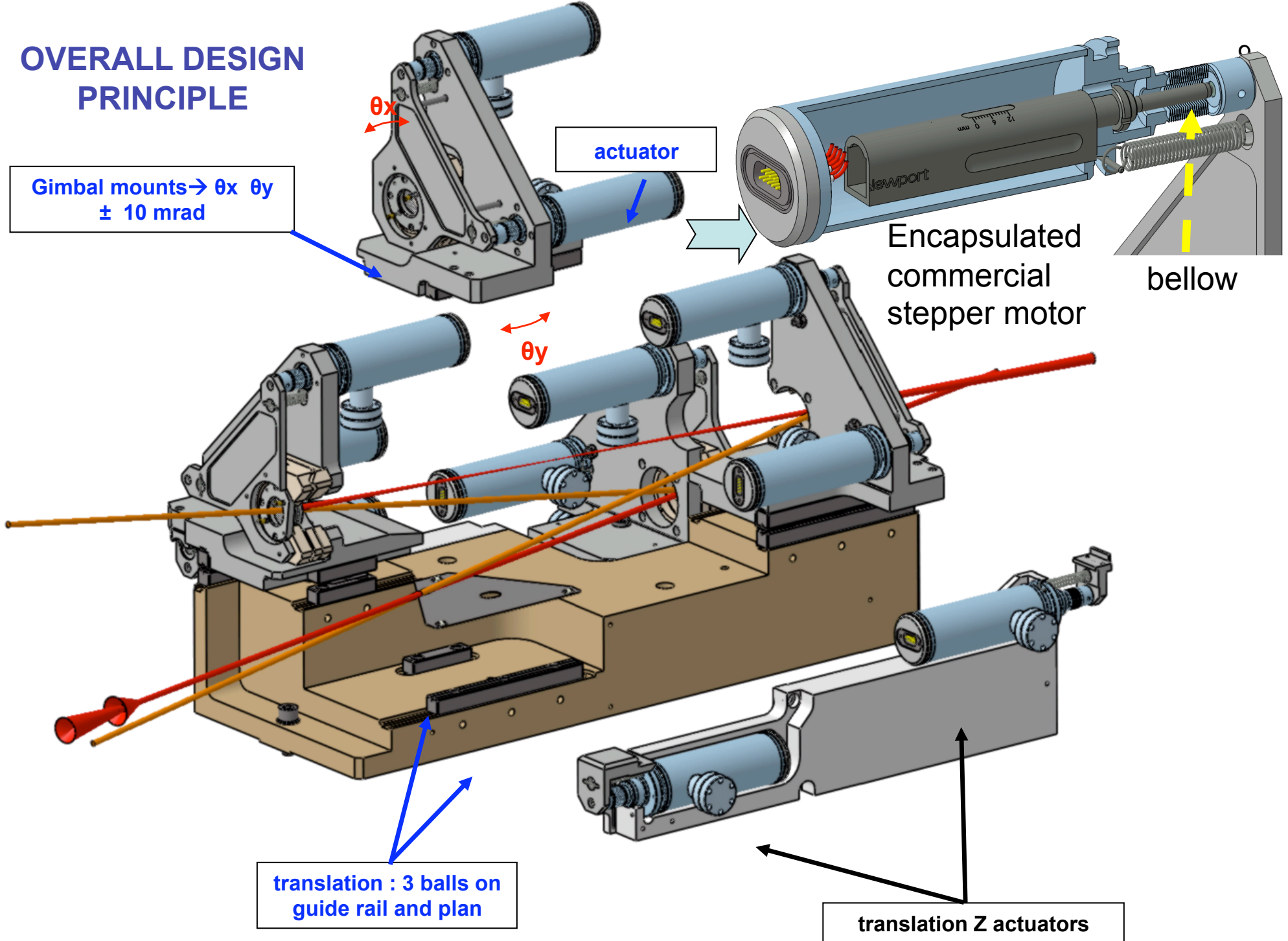

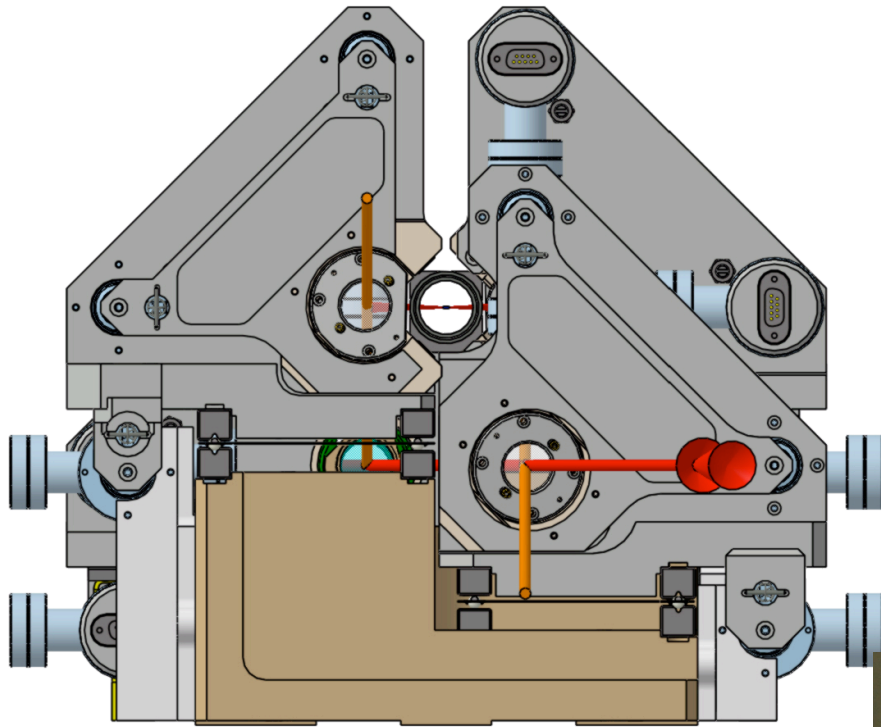

**Place for
ATF beam pipe**

**Mirror mount troncated
to decrease incident
angle : 8°**

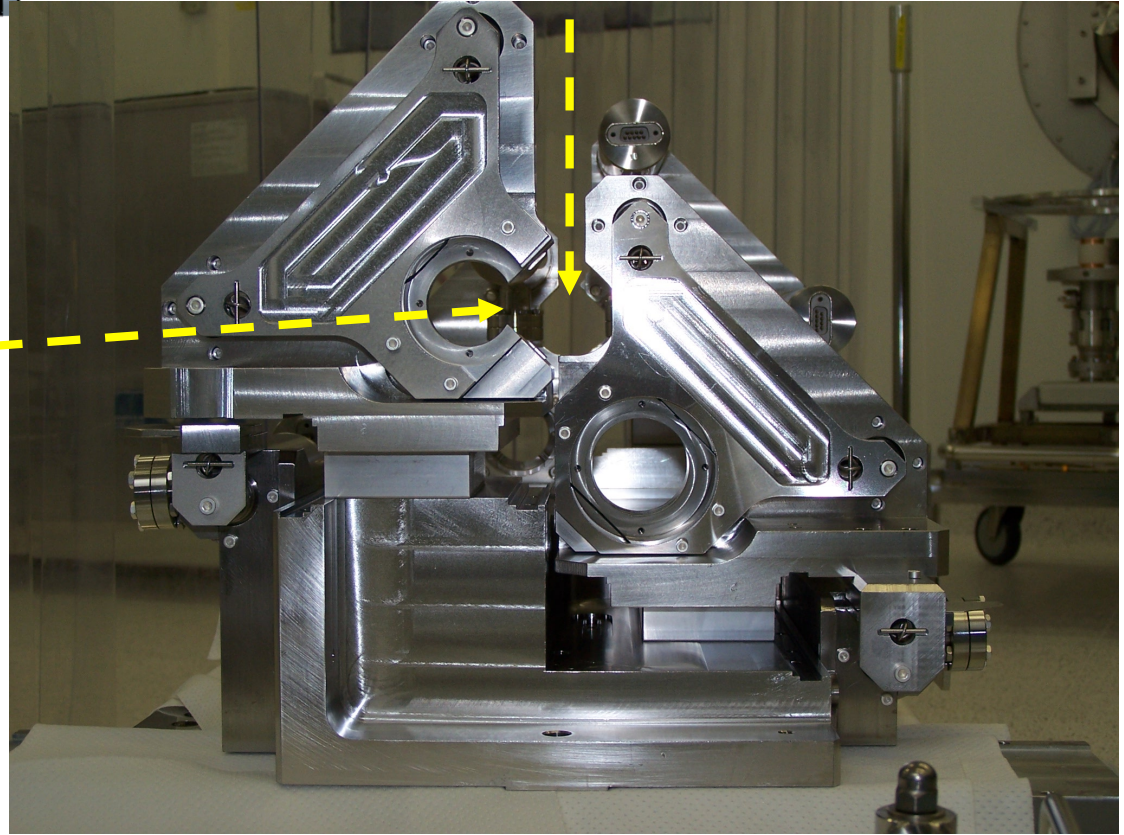

Vacuum vessel for ATF

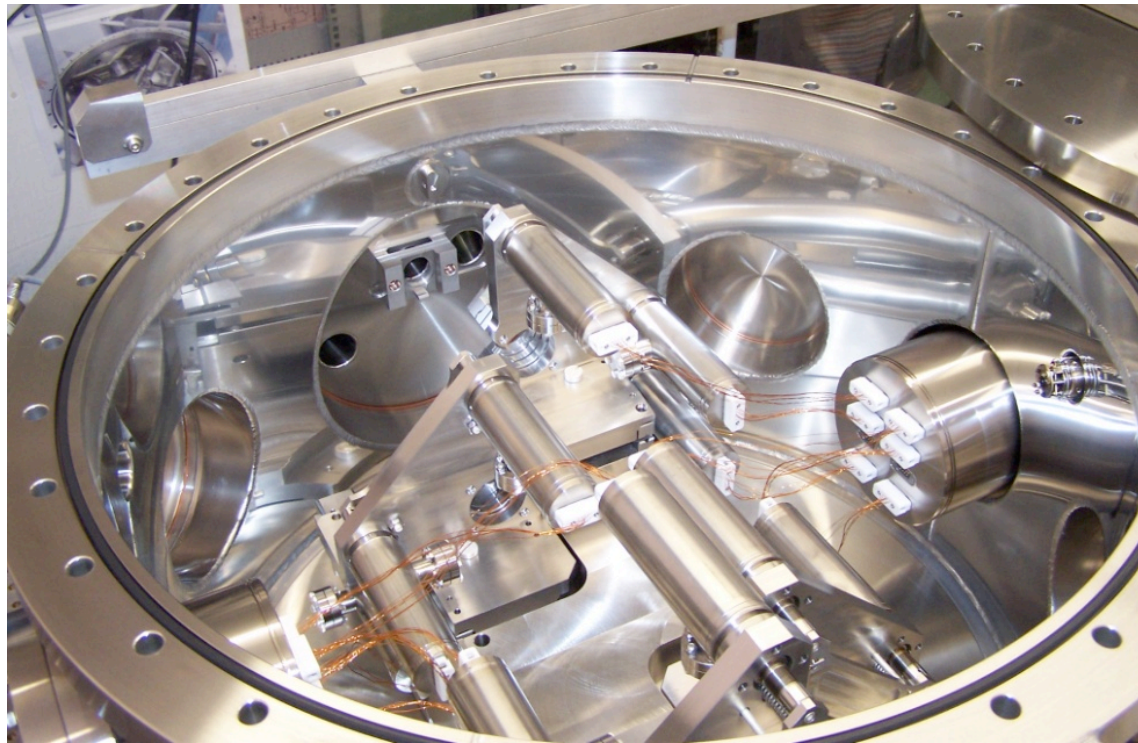
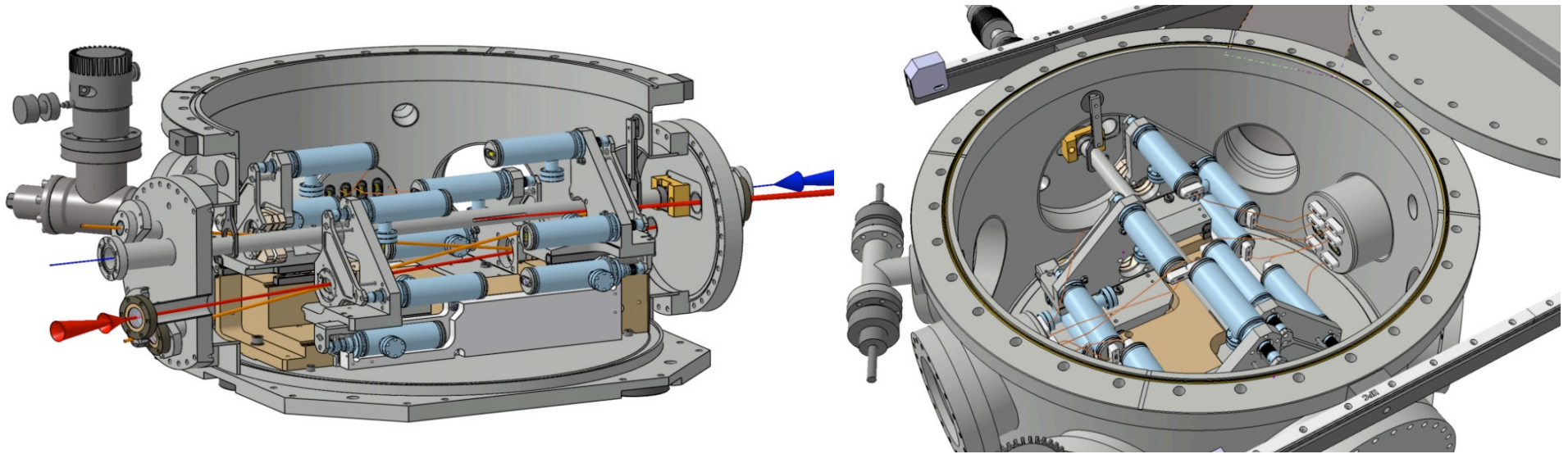

Implementation at ATF

Funahasi-san's ATF micrometric table mount system

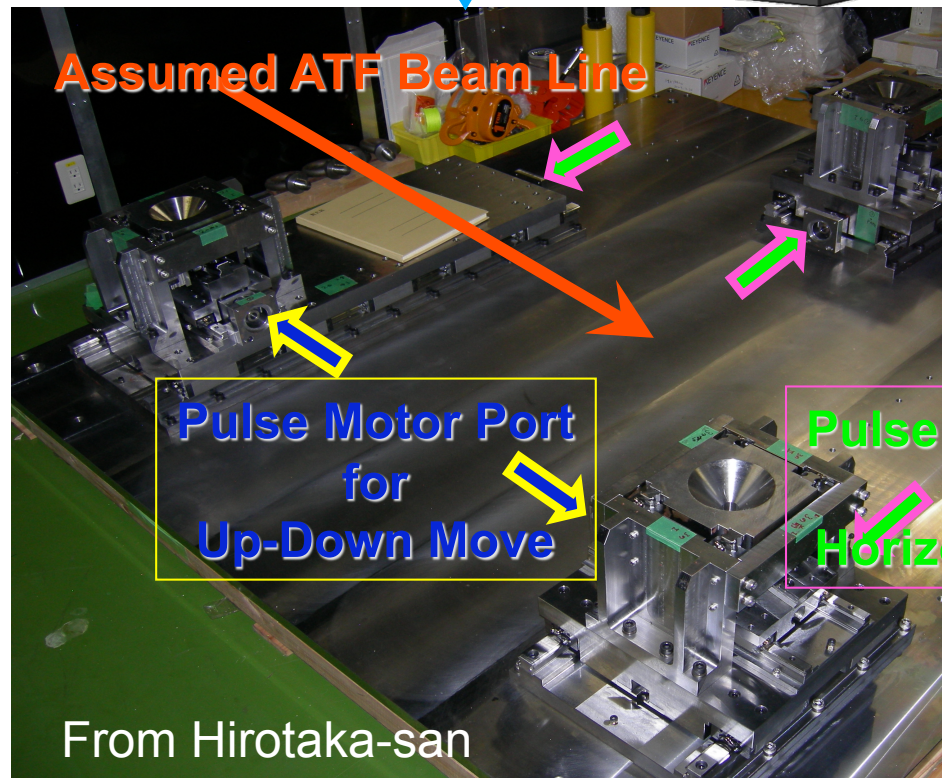
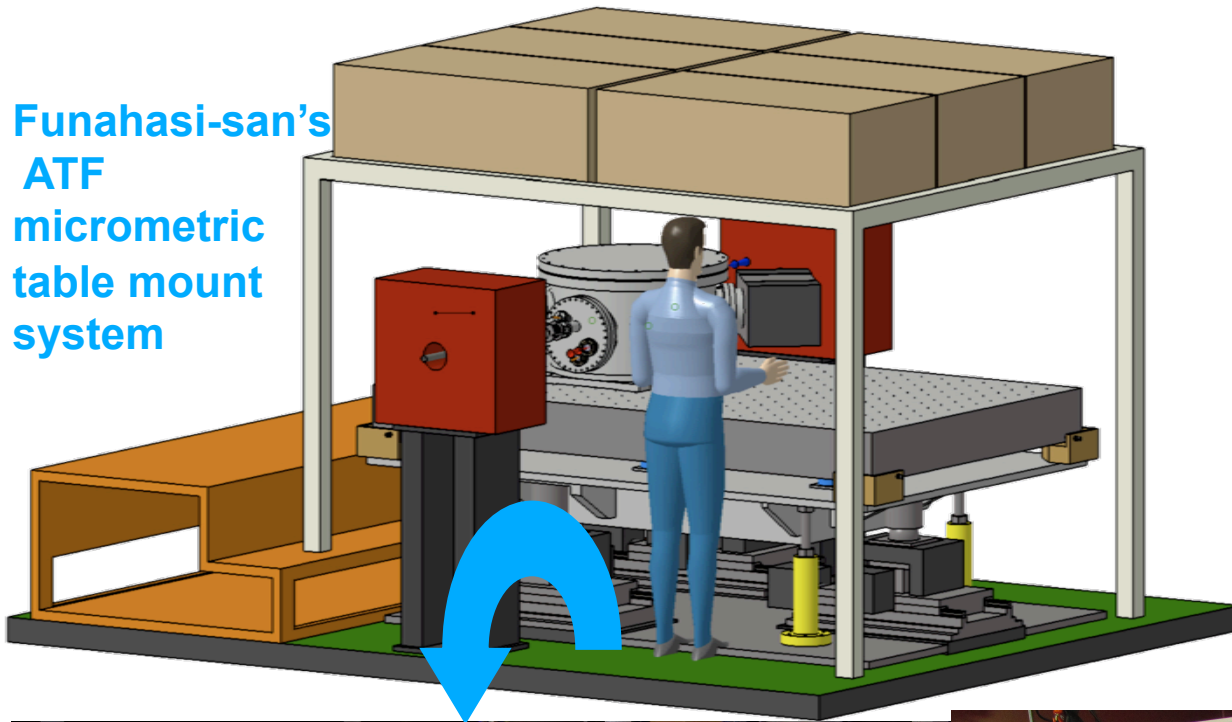

The optical scheme

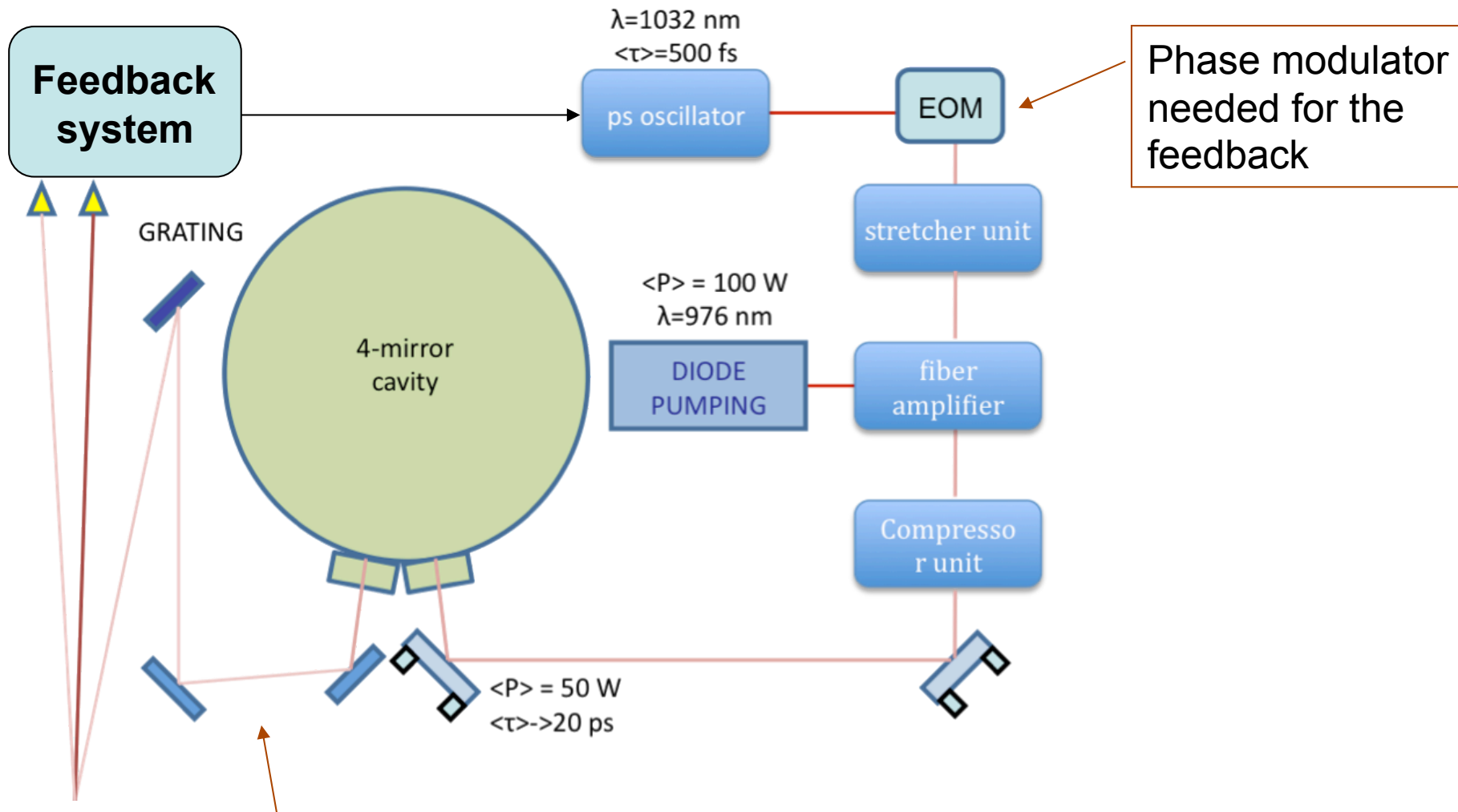

- Signal reflected by the cavity used to build the **laser/cavity feedback signal**:
 - interference between the modulated incident laser beam
 - AND the leakage on the beam circulating inside the cavity

The laser amplification R&D

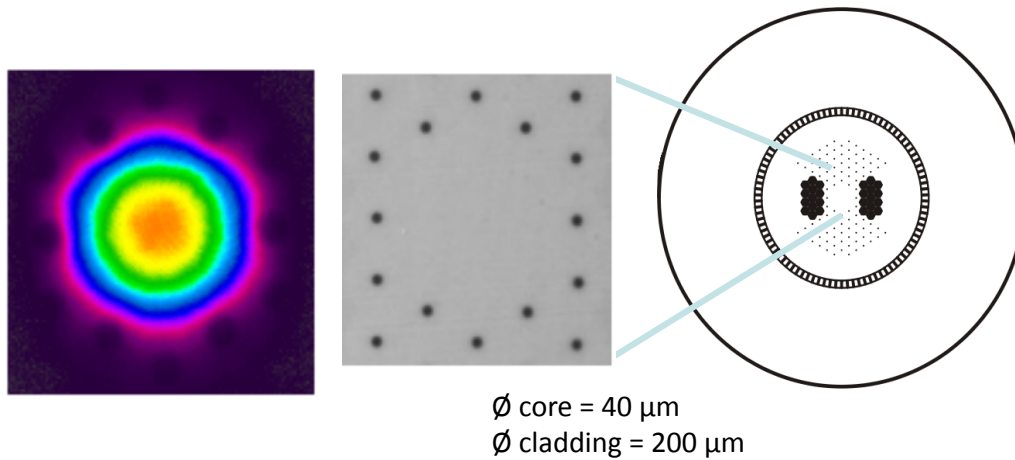

We use Ytterbium doped photonic crystal fiber as amplifier

- We obtained 200W but spot was not stable
- We fix the power to ~50W to get stable laser beam
- Thermal control issues to be solved before increasing power
- Also damage protection issues are not easy to solve at very high power (we broke many fibers...)
- Recent publication shows 800W average power (11 μJ /pulse) with same techniques (Limpert, OL35(2010)94)
- but we need long term stability and reliability...

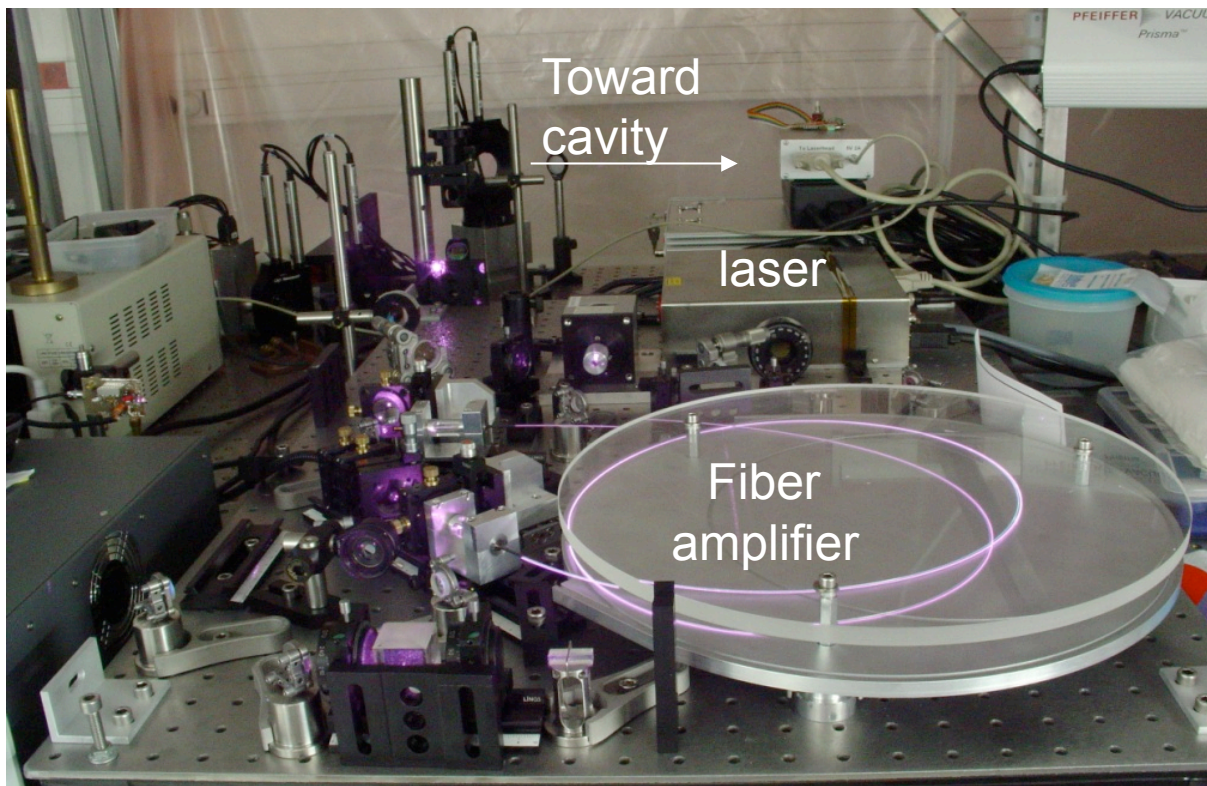

→ technological R&D

Digital Pound-Drever-Hall feedback

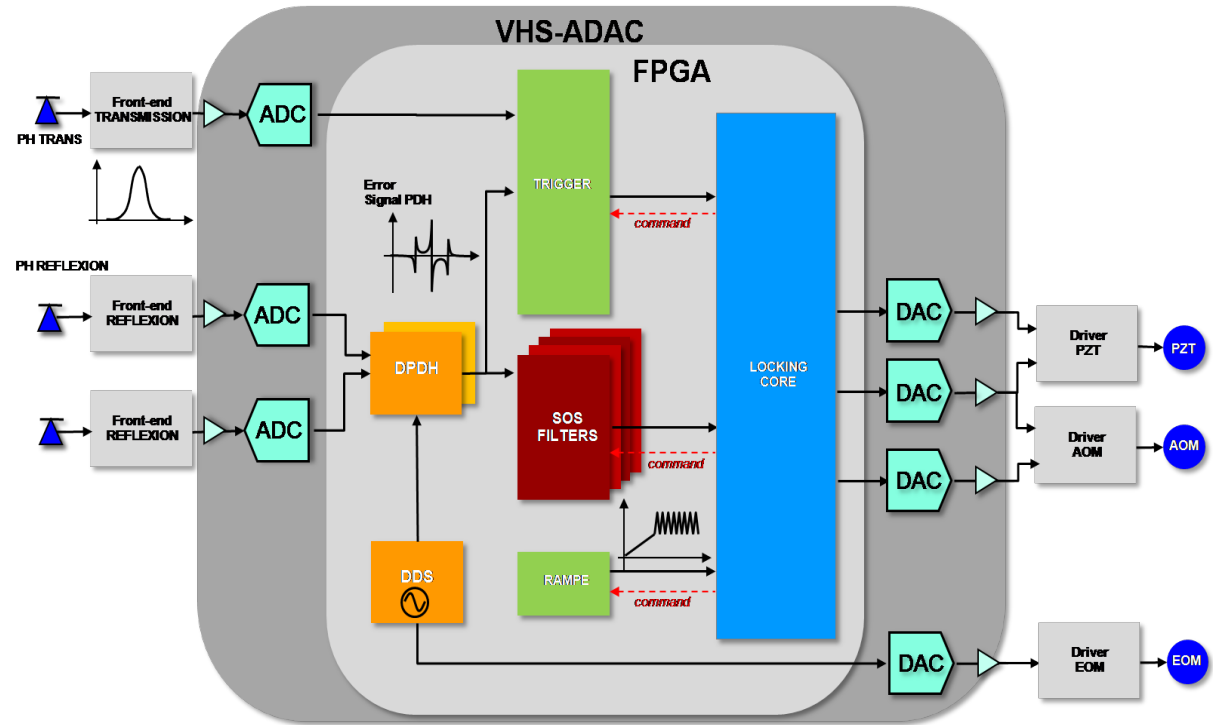
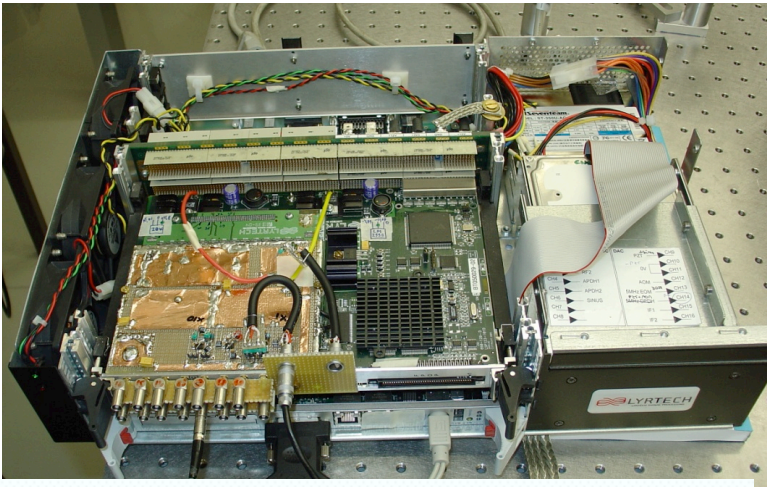

Feedback on laser frequency

Clk = 100 MHz
 8x ADC 14 bits
 8x DAC 14 bits
 FPGA Virtex II

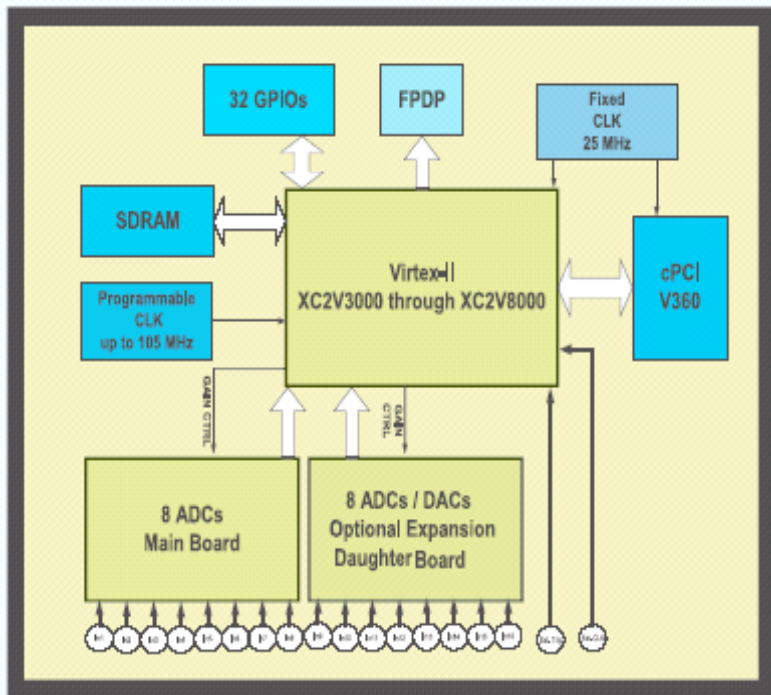

Cavity locked (*gain* ~ 10000)

- Digital feedback (5k lines of VHDL code)
- Already $\Delta f_{\text{rep}}/f_{\text{rep}} \sim 10^{-11} \rightarrow \Delta f_{\text{rep}} \sim 7.6\text{mHz}$ for $f_{\text{rep}} \sim 76\text{MHz}$

- We developed this feedback system to lock a Ti:sapph laser oscillator to a 30000 finesse cavity at Orsay
- We have also locked at Orsay the 4-mirror cavity installed at ATF

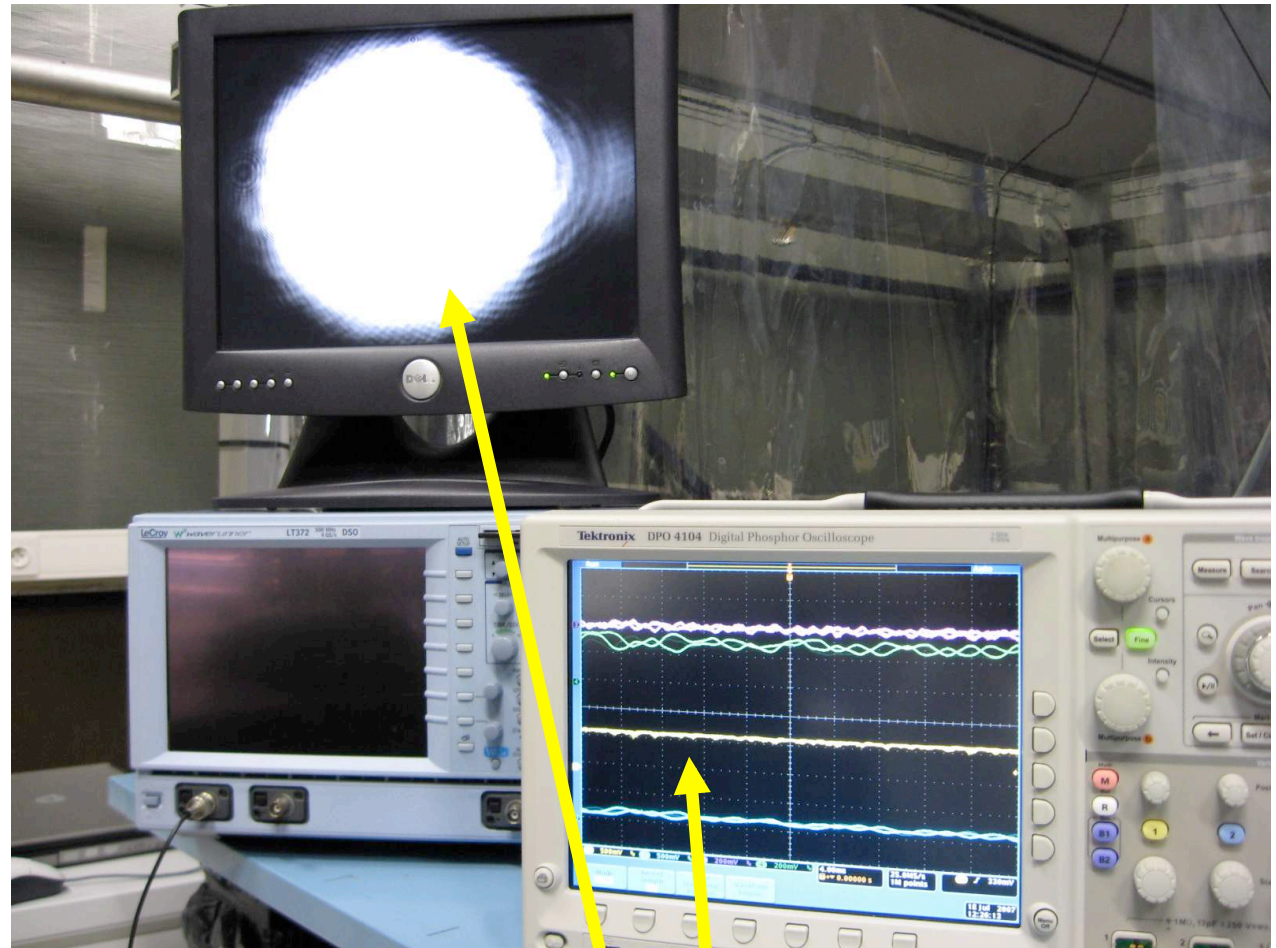

**Cavity locked
With gain 10000**

Installation of the experiment at ATF

Sunday 25th July
Arrival of the
french team
at KEK



ATF tunnel opened on
27th July

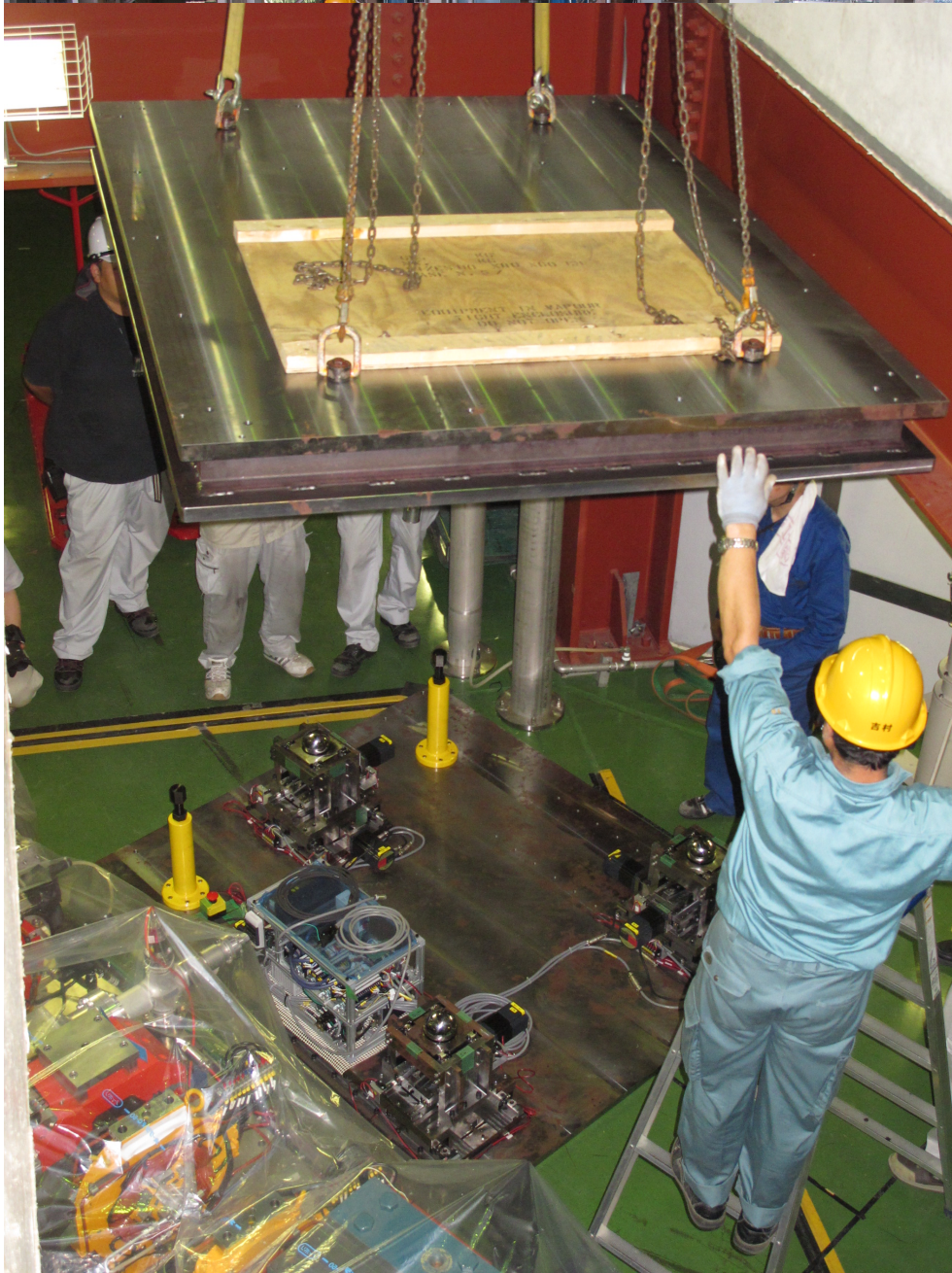

Cavity installed on 28th July

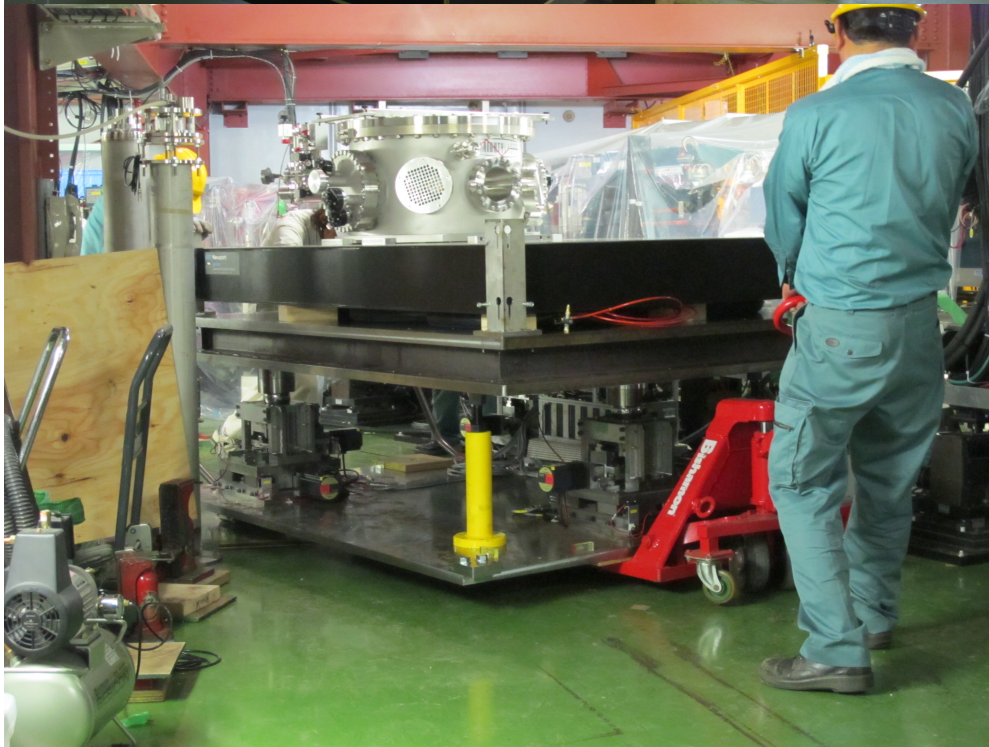

And aligned in ATF ring

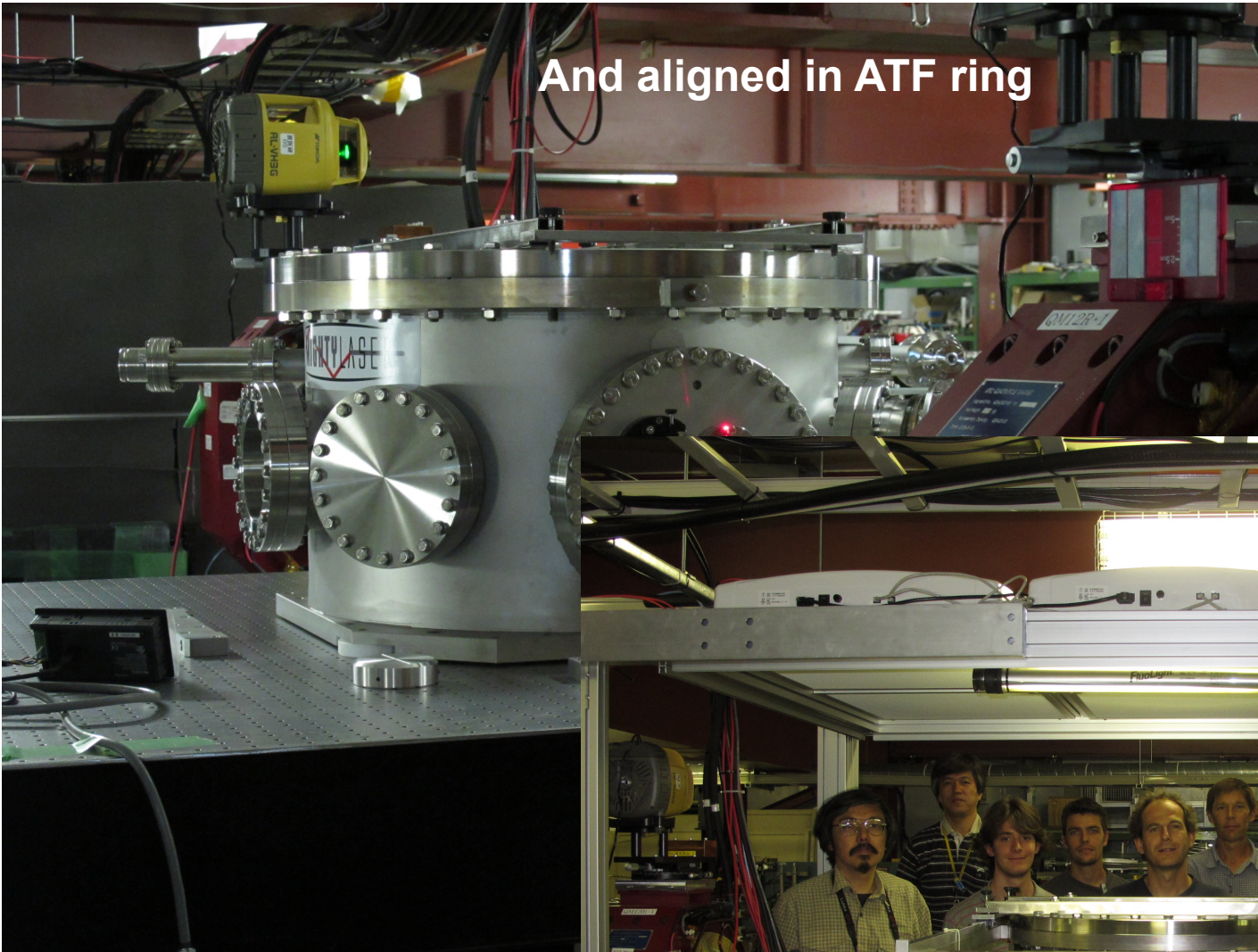

**29th July: after 3 days
ready to
install the experiment**

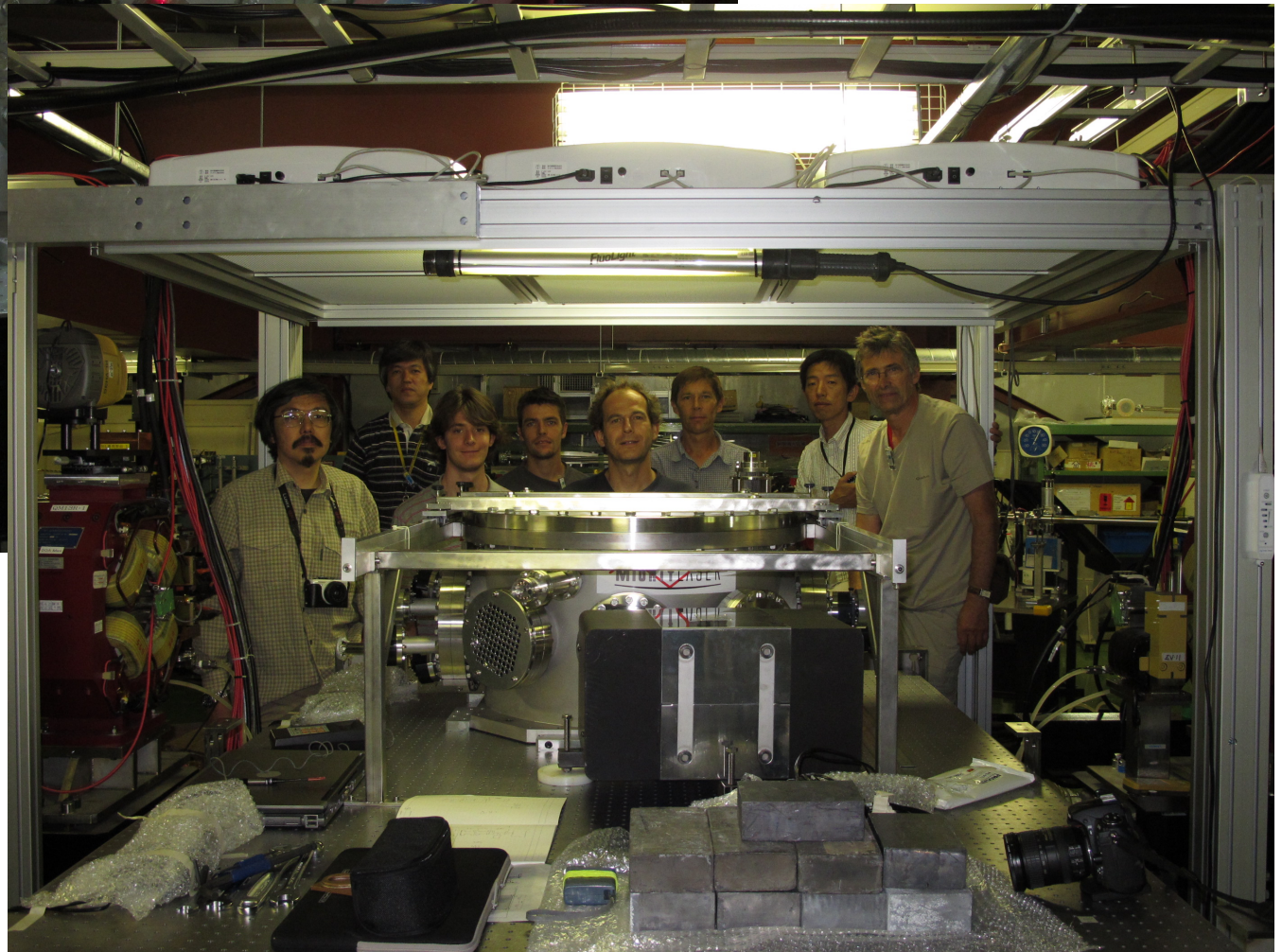

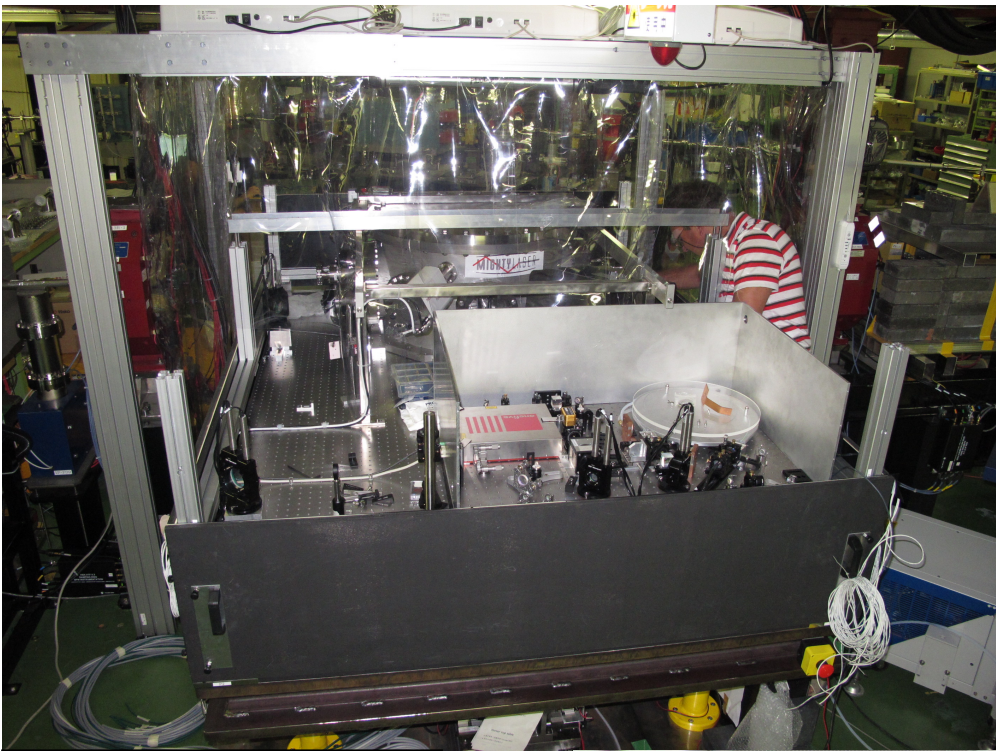

**Optical elements
mounted**

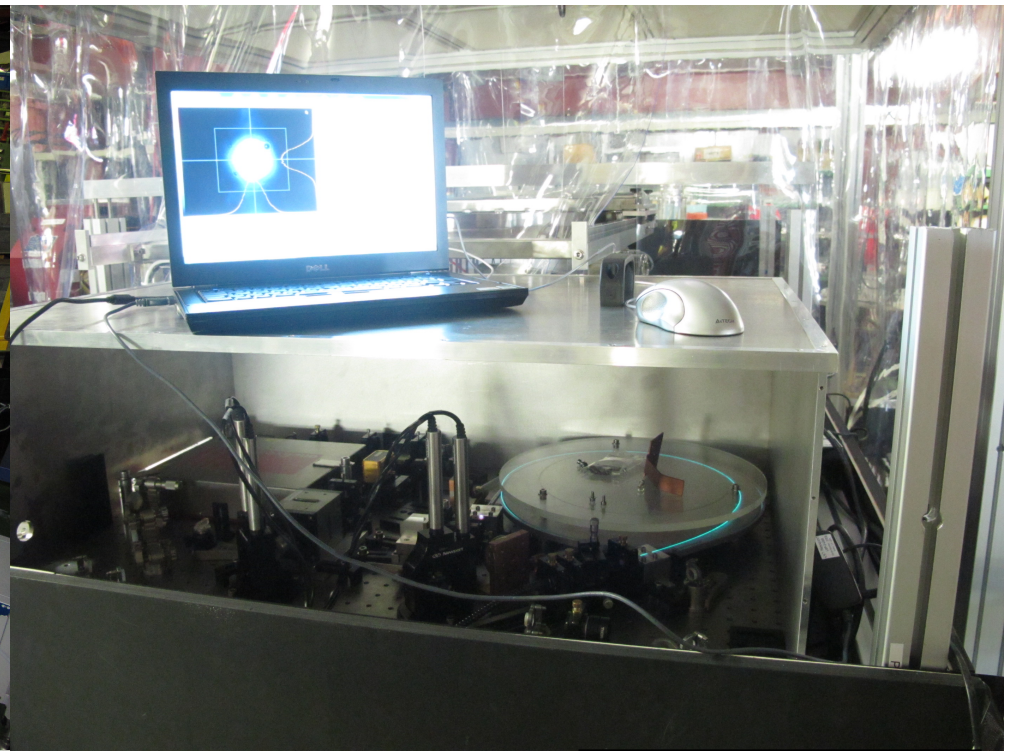

**10th August
laser turned on
(low power)
To start cavity
mirrors
installation**



11th August : The laser passes through the 5mm beam pipe aperture
→ cavity mirrors aligned

23

Infrared laser marker before the slit

Infrared laser marker after the slit

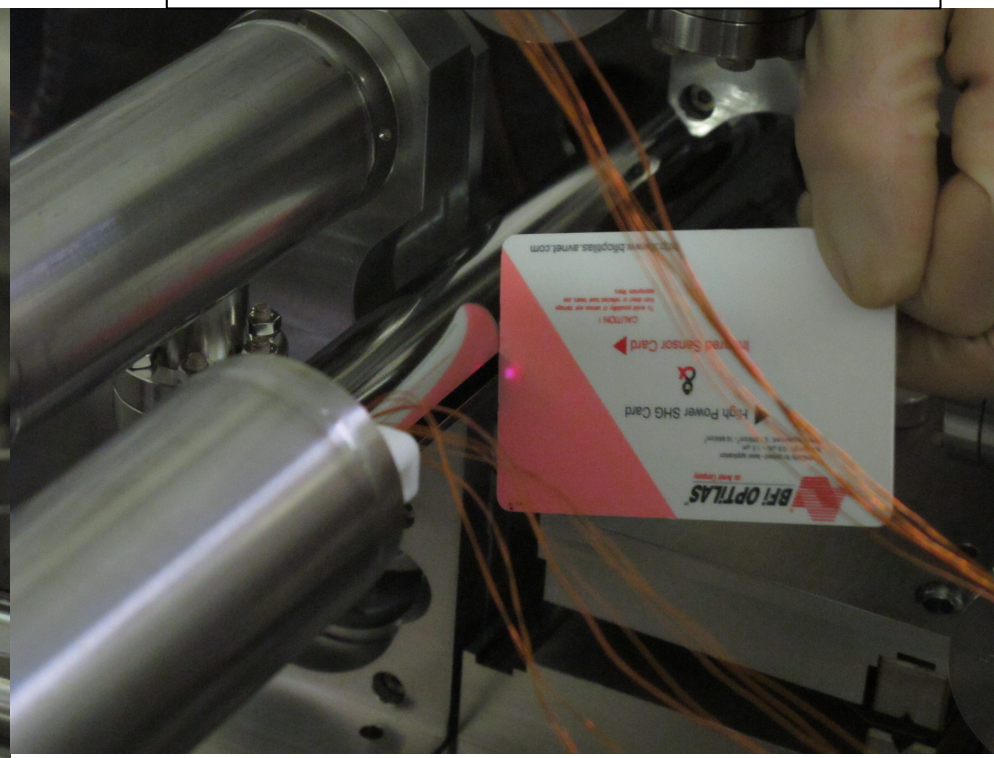

Laser inspection tomorrow (17/08)

Summary

Compton scattering is a very useful process

- But X-section is small → huge laser power required → R&D
- There is now a new 4-mirror fabry-perot cavities in ATF to contribute to this R&D effort

**2-mirror cavity
pulsed laser**

**2X 2-mirror
cavities
cw laser
(laser-wire)**

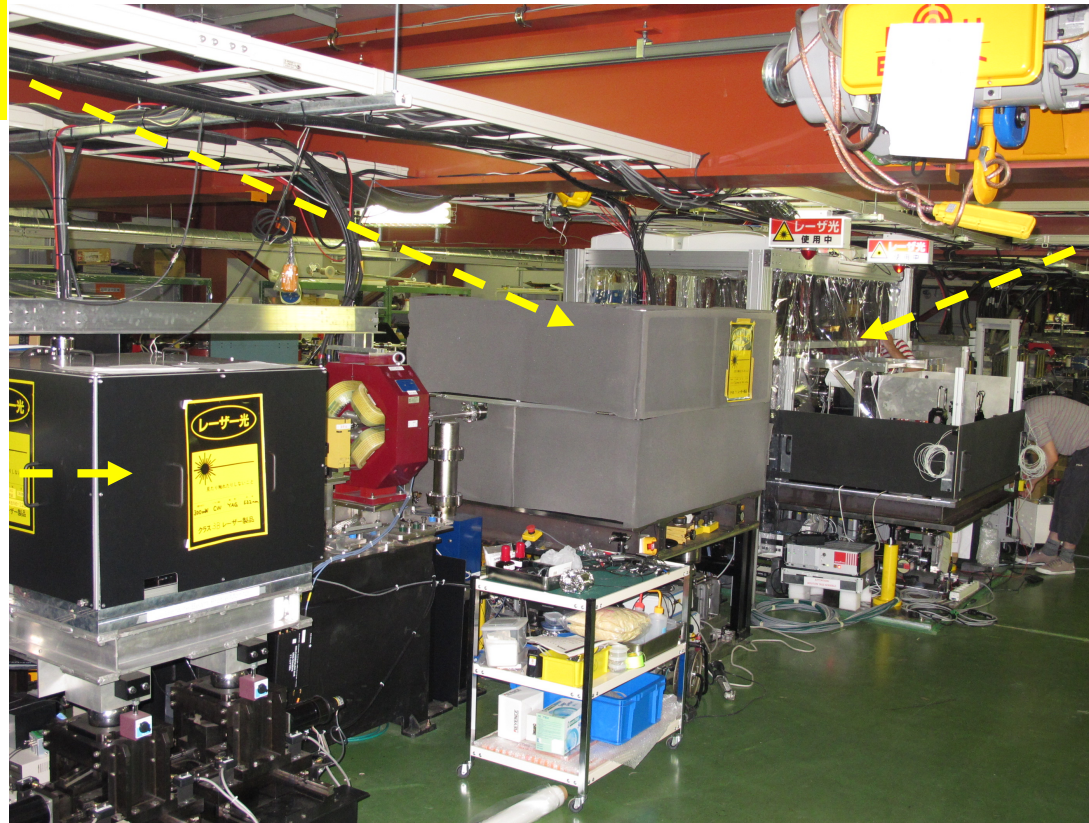

**4-mirror cavity
pulsed laser**

The new cavity has 4 mirrors and is non-planar to match requests of futur Compton e⁺ polarised sources or compact X-ray machines

Thanking

The whole french team would like to thanks the ATF group, KEK colleagues and KEK administration for their very efficient and competent collaboration, contribution and technical support.

And for the kindness of their welcome...

We also thanks the FJPPL who helped us to establish the French-Japanese collaboration since 2006

French fundings for the R&D project

